

PeakTech®

Unser Wert ist messbar...

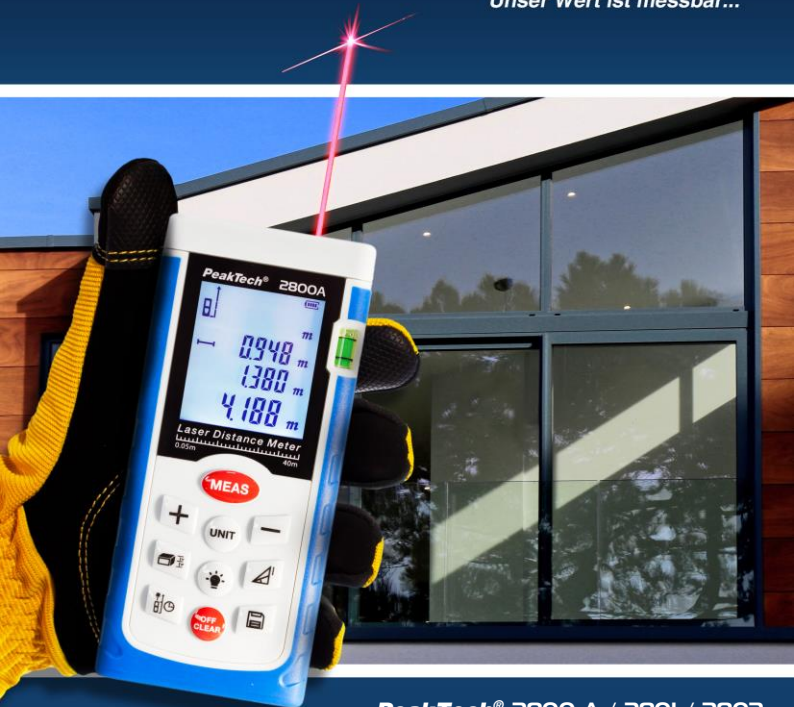

PeakTech® 2800 A / 2801 / 2802

**Bedienungsanleitung/
Operation Manual**

**Laser-Entfernungsmesser/
Laser-Distance Meter**

1. Safety Precautions

This product complies with the requirements of the following European Community Directives: 2004/108/EC (Electromagnetic atibility) amended by 2004/22/EC (CE-Marking). Pollution degree 2.

To ensure safe operation of the equipment, the following safety precautions must be observed.

Damages resulting from failure to observe these safety precautions are exempt from any legal claims whatever.

- * Handle the device with extreme caution when it is switched on (laser beam emission)
- * Never point the laser beam at the eyes of humans or animals.
- * Do not point the laser beam at gaseous substances or gas containers (risk of explosion).
- * Keep the laser beam away from reflective objects (risk of injury to the eyes).
- * Avoid contact with the laser beam (do not expose the body to laser beam emissions).
- * Never let children play with laser-emitting devices unsupervised.
- * Do not operate the meter before the cabinet has been closed and screwed safely as terminal can carry voltage.
- * Comply with the warning labels and other info on the equipment.
- * Do not subject the equipment to shocks or strong vibrations.
- * Do not operate the equipment near strong magnetic fields (motors, transformers etc.).
- * Keep hot soldering irons or guns away from the equipment.
- * Allow the equipment to stabilize at room temperature before taking up measurement (important for exact measurements).
- * Replace the battery as soon as the battery indicator "BAT" appears. With a low battery, the meter might produce false reading that can lead to electric shock and personal injury.

- * Fetch out the battery when the meter will not be used for long period of time.
- * Periodically wipe the cabinet with a damp cloth and mild detergent. Do not use abrasives or solvents.
- * The meter is suitable for indoor use only
- * Do not store the meter in a place of explosive, inflammable substances.
- * Do not modify the equipment in any way
- * Do not place the equipment face-down on any table or work bench to prevent damaging the controls at the front.
- * Opening the equipment and service – and repair work must only be performed by qualified service personnel
- * Do not use the instrument without instruction
- * Avoid deliberate or irresponsible behavior on scaffolding, when using ladders, when measuring near machines which are running, or near parts of machines which are unprotected
- * Avoid aiming directly into the sun
- * Avoid inadequate safeguards at the surveying site
- * **Measuring instruments don't belong to children hands.**

Cleaning the cabinet

Clean only with a damp, soft cloth and a commercially available mild household cleaner. Ensure that no water gets inside the equipment to prevent possible shorts and damage to the equipment.

Laser Classification

The Laser Distance Meter produced a visible laser beam which emerges from the front of the instrument.

Laser Class 2 products

Do not look into the laser beam and do not point the laser beam unnecessarily at other people. The eyes are normally protected by aversion reactions, including the blink reflex. Be sure to read the corresponding warning notices on the device and in these operating instructions and make them accessible to subsequent users as well.



Warning!

Looking directly into the beam with optical aids (e.g. binocular, telescopes) can be hazardous.

Precautions: Do not look directly into the beam with optical aids.

Caution!

Looking into the beam may be hazardous to the eyes.

Precautions: Do not look into the laser beam. Make sure the laser is aimed above or below eye level.

2. Features

This professional Laser Distance Meter with LCD-Display and backlight is designed for high accuracy, one person distance measurement and as estimating tool to measure remote and difficult reachable places. Shortcut keys for addition, subtraction, Pythagoras, area and volume calculation allow a fast and reliable measurement. 99 recorded readings can be stored to the internal memory by keystroke to recall these values again later. In addition, a 90° angle try square at the lower end of the measuring device can be expanded in order to ensure a precise alignment to the measuring point.

Features

- Area, volume calculation
- Indirect measurement using Pythagoras
- Addition / Subtraction
- continuous measurement
- Min / Max Distance Tracking
- Display illumination and multi-line display.
- Audible alerting signal
- Measurements in m (meters); in (inches) or ft (Foot)

3. Technical Data

Range:	0.05m to 60m (P 2800A) 0.05m to 60m (P 2801) 0.05m to 80m (P 2802)
Display:	multi function display
Measuring Accuracy:	+/- 1,5mm, typically
Measuring units:	m (meter), in (inches), ft (feet)
Memory:	99 values
Laser:	Class 2
Laser type:	620 ~ 680 nm, < 1mW
Auto laser switch-off:	after 20 sec.
Auto instrument switch-off:	after 150 sec.
Storage Temperature:	- 20°C ... 60°C < 80% RH
Operating Temperature:	0°C ... 40°C < 85% RH
Battery Life:	up to 8000 measurements
Operation voltage:	2 x 1,5 V (AAA) batteries
Dimensions (WxHxD):	54 x 118 x 27mm
Gewicht:	ca. 135g

4. Front Panel Description



- 1.) Lens for laser (on the top panel)
- 2.) Multi-function display
- 3.) Keypad
- 4.) Rubberized grip surface
- 5.) Water level
- 6.) 90° Try square

4.1 Display Symbols

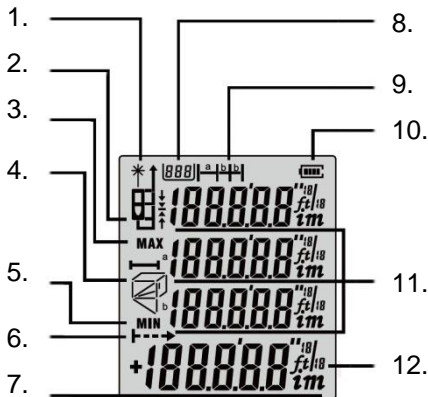

- 1.) Laser is ON
- 2.) Reference top, middle, bottom, angle
- 3.) Maximum
- 4.) Area, Volume, and Pythagoras
- 5.) Minimum
- 6.) Continuous measurement
- 7.) Main display
- 8.) Memory number
- 9.) Distance default
- 10.) Battery status
- 11.) Auxiliary display
- 12.) Measuring Unit

4.2 Area, Volume & Pythagorean measurement

 Area measurement

 Volume measurement

 Indirect measurement

 Indirect (second) measurement

5. Keypad

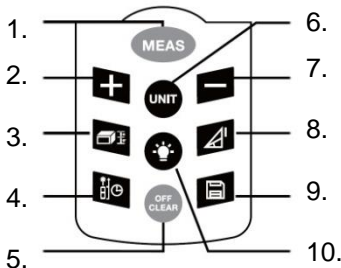

- 1.) On / Meas – button
- 2.) Plus (+) – button
- 3.) Area / Volume – button
- 4.) Reference point / Delayed Measurement
- 5.) Off / Clear button
- 6.) Unit – button
- 7.) Minus (-) – button
- 8.) Pythagoras measurement
- 9.) Memory – button
- 10.) Backlight - button

6. Initial Operation and Setting

6.1 Switching on and off

turn on the instrument and laser with the "ON / MEAS" key (1),.

If you hold down the "Clear / Off" button (5) for 2 sec., The unit turns off.

The instrument automatically turns off when it is not used for 150 seconds.

6.2 Clear Key

The last action is canceled and the displayed data is erased. If you press the Clear / Off "button (5) in the" Memory " mode, the stored value is erased.

6.3. Setting the reference level

The default setting for the reference level is the lower edge of the instrument. Press the "Reference" button (4) to cycle through the four reference settings.

Whenever you change the reference setting a beep sounds. After restarting the device, the reference level automatically returns to the default setting (lower edge).

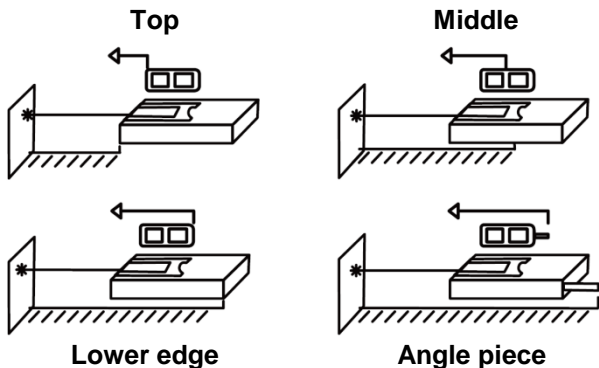

6.4 Display Illumination

Press "Backlight"-button (10) and the backlight of the display can be switched on or off, user can trigger the function when there is a darkness situation. The value is clear visible on the LCD.

6.5 Distance Unit Setting for Instrument

Press the "UNITS"-button (6) longer to change the next type of unit, m, ft, In, ft+In then continue to click the button for the next unit selection.

6.6 Single Distance Measurement

Press the "ON/MEAS"-button (1) to activate the laser.

Press again to trigger the distance measurement. The measured value is displayed immediately.

6.7 Continuous Measurement & Max / Min Measurement

The continuous measurement function (tracking) is used for the transferring of measurements, e.g., from construction plans. In continuous measurement mode, the measuring tool can be moved to the target, whereby the measured value is updated approx. every 0,5 seconds in the third line. The corresponding minimum and maximum values are displayed dynamically in the first and second line. As an example, the user can move from a wall to the required distance, while the actual distance can be read continuously. For continuous measurement, push the "ON/MEAS"-button (1) until the min/max symbol is displayed or the "Clear/Off"-button (5) again to stop the function.

6.8. Addition/Subtraction of Areas

Make your desired distance measurement.

The next length measurement is added to the previous measurement with the "+" - button (2) or subtracted from the previous measured value with the "-" key (7) value.

After the addition / subtraction, the system automatically switches back to the normal measurement mode.

6.9 Addition/Subtraction of Areas

Set the meter to Area Calculation via the corresponding key (3).

Measure the first area until the calculation is shown in the main display (Figure 1).

Click the "+" - button (2) and carry out the second area measurement (Figure 2).

Finally, press the "Meas" key (1) and the added measurement of both areas is displayed.

For the subtraction of surfaces, proceed as described above, just by pressing the "-" - button (7) instead of the "+" - button (2)

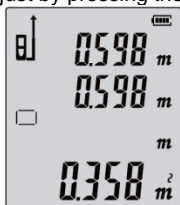

Fig. 1

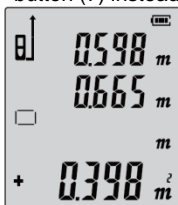

Fig.2

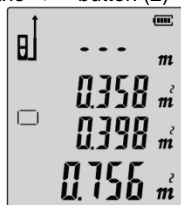

Fig.3

6.10 Area Measurement

Press the "Area- / Volume" button (3).

The area symbol appears on the display:



Press the "ON/MEAS" key (1) for the first length measurement (eg length).

Press the "ON/MEAS" key (1) again for the second length measurement (eg width).

The result of the area measurement is shown in the third line, the individual measured values are displayed in lines 1 and 2.

6.11 Volume Measurement

Press for volume measurement the "Area- / Volume" button (3) twice until the symbol for volume measurement appears in the display:



Press the "ON/MEAS" key (1) for the first distance measurement (eg length) and then, again the "ON / MEAS" key (1) for the second distance measurement (eg width).

The result of the area measurement of already measured values will be displayed in the main display.

Press the "ON/MEAS" key (1) again to measure the third distance(eg height). The value is displayed in the third line.

The result of the volume measurement will be shown in the main line, the three previously measured readings are displayed in rows 1, 2 and 3.

6.12 Pythagorean measurement

1. Indirect measurement for determining a distance (x) using 2 auxiliary measurements.

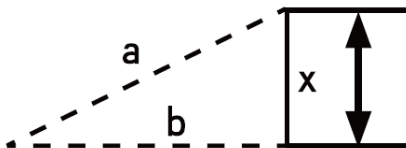

Example: Measuring heights at which the measurement of two or three measurements is required. Follow these steps:

Press the "Pythagorean" button (8). The display shows  The distance to be measured (a) flashes in the symbol.

Aim at the upper point and make the measurement.

After the first measurement the value is adopted. Now the second distance to be measured (b) flashes. Keep the instrument as horizontal as possible.

Press the "ON/MEAS" key (1) to measure the distance of the horizontal point. The result of the function (x) is displayed in the summary line.

2. To determine the hypotenuse (x) press the "Pythagorean" button (8) again until the icon for the cathetus (a) flashes:

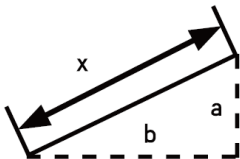

Measure to the first cathetus (a) with the "ON/MEAS" key (1). Then flashes the second cathetus (b) that you measure with the "ON/MEAS" key (1). In the main line now the result of the hypotenuse (x) is displayed.

6.13 Indirect Measurement – length (x) using 3 Measurements

1. Press the "Pythagoras" button (8) three times until the indicator for "indirect measurement by three readings" switches to: 

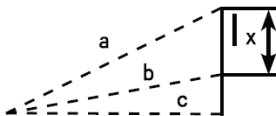

The distance to be measured (a) flashes in the symbol. Aim at the upper point of the measured distance (x) and trigger the measurement of the distance (a). After the first measurement the value is adopted. Measure the distance (b) the lower point of the track (x) and press the "ON/MEAS" key (1). The second value is now displayed. Keep the instrument as horizontal as possible now. Press the "ON/MEAS" key (1) to the distance (c) measure. The result of the function (x) is shown in the summary line.

2. To measure the total length (x) of two short sides using three related measurements: 

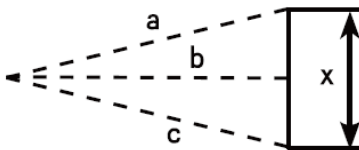

Press the "Pythagoras" button (8) four times, until the display for indirect measurement switches through the three readings. The distance to be measured (a) flashes in the symbol. Aim at the upper point of the measured distance (x) and trigger the measurement of the distance (a). After the first measurement the value is adopted. Measure the distance (b). Keep the instrument as horizontal as possible and then press the "ON/MEAS" key (1). Press the "ON/MEAS" key (1) to measure the distance (c) the lower point of the track (x).

The result of the function (x) is shown in the summary line.

6.14 readings memory

In order to store a displayed measurement value to the internal memory of 99 readings, press the "Memory" button (9) for about 3 seconds until the memory icon appears. Go on as necessary, with all to be saved measurements and continue until the memory is exhausted.

To recall a stored measured value, press and release the "Memory" button (9) briefly. The requested measured value is now displayed in the main line, where the storage number (1 - 99) is shown in the upper left corner of the display. Switch through the stored values with the "+" and "-" keys.

To delete a stored measured value, press the "Off/Clear" button (5).

6.15 Stacking Out - Preset distance

If you want to preset a certain measuring distance determined and then for example change the distance between the laser distance meter on a moving platform, hold down the "Area/ Volume" button (3) until the stacking icon appears in the display:

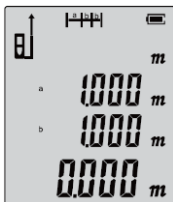

Change the value of the distance (a) with the "-" and "+" - keys and confirm the value with the "ON/MEAS" key (1). Now change the value for the flashing second distance (b) also with the keys "-" and "+". Confirm again with "ON/MEAS" key (1).

Now the distance measurement starts, which shows the remaining distance to reach the selected distance in the main display. If the meter is placed too far away from the set value, an icon appears that you should move forward. Are you too close, an icon appears and shows you to move backwards:

Move forwards: ↑ Move backwards: ↓

Once the desired distance achieved following symbol appears:



6.16 Delayed Measurement

In order to trigger a time-delayed measurement, hold down the button (4) until the timing seconds-selection of the time delay is displayed:

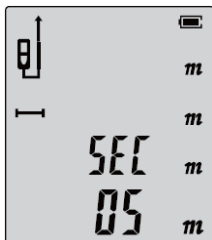

Now use the "-" and "+" - buttons to set the seconds to the time-delayed measurement and confirm by pressing the "ON/MEAS" key (1). Now begins a countdown to zero, in which the measurement is initiated

7. Measuring Conditions

Measuring Range

The range is limited to 60 m (P 2801) or 80m (P 2802).

At night or dusk and if the target is in shadows the measuring range without target plate is increased. Use a target plate to increase the measurement range during daylight or if the target has poor reflection properties.

Target Surfaces

Measuring errors can occur when measuring toward colorless liquids (e.g. water) or dust free glass, Styrofoam or similar semi-permeable surfaces. Aiming at high gloss surfaces may deflect the laser beam and lead to measurement error.

Against non-reflective and dark surfaces the measuring time may increase.

Care

Do not immerse the instrument in water. Wipe off dirt with a damp, soft cloth. Do not use aggressive cleaning agents or solutions. Handle the instrument as you would a telescope or camera.

8. Troubleshooting

Code	Cause	Corrective measure
Err1	Received signal too weak, measurement time too long.	Use target plate
Err2	Received signal too strong	Target too reflective (use target plate)
Err3	Battery weak	Replace batteries
Err4	Temperature too high / Low	Cool down or warm up the instrument
Err5	Pythagorean meas. error	Hypotenuse must be longer than Cathete
Err6	Record damaged	Switch on/off the device several times, if the symbol still appears, please contact your dealer for assistance.

9. Battery Replacement

* When it is necessary to replace the battery, battery-symbol "  " will appear on the display.

1) Remove battery compartment lid.

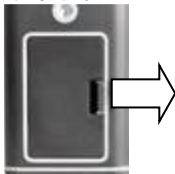

2) Insert batteries, observing correct polarity.



3) Close the battery compartment again.

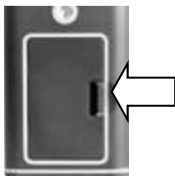

If the instrument is not be used for any extended period, remove batteries.

9.1 Notification about the Battery Regulation

The delivery of many devices includes batteries, which for example serve to operate the remote control. There also could be batteries or accumulators built into the device itself. In connection with the sale of these batteries or accumulators, we are obliged under the Battery Regulations to notify our customers of the following:

Please dispose of old batteries at a council collection point or return them to a local shop at no cost. The disposal in domestic refuse is strictly forbidden according to the Battery Regulations. You can return used batteries obtained from us at no charge at the address on the last side in this manual or by posting with sufficient stamps.

Contaminated batteries shall be marked with a symbol consisting of a crossed-out refuse bin and the chemical symbol (Cd, Hg or Pb) of the heavy metal which is responsible for the classification as pollutant:



1. "Cd" means cadmium.
2. "Hg" means mercury.
3. "Pb" stands for lead.

All rights, also for translation, reprinting and copy of this manual or parts are reserved.

Reproduction of all kinds (photocopy, microfilm or other) only by written permission of the publisher.

This manual considers the latest technical knowing. Technical changings which are in the interest of progress reserved.

We herewith confirm, that the units are calibrated by the factory according to the specifications as per the technical specifications. We recommend to calibrate the unit again, after 1 year.

© PeakTech® 07/2021 MP/HR/Ehr