

PAStack Wheel Set

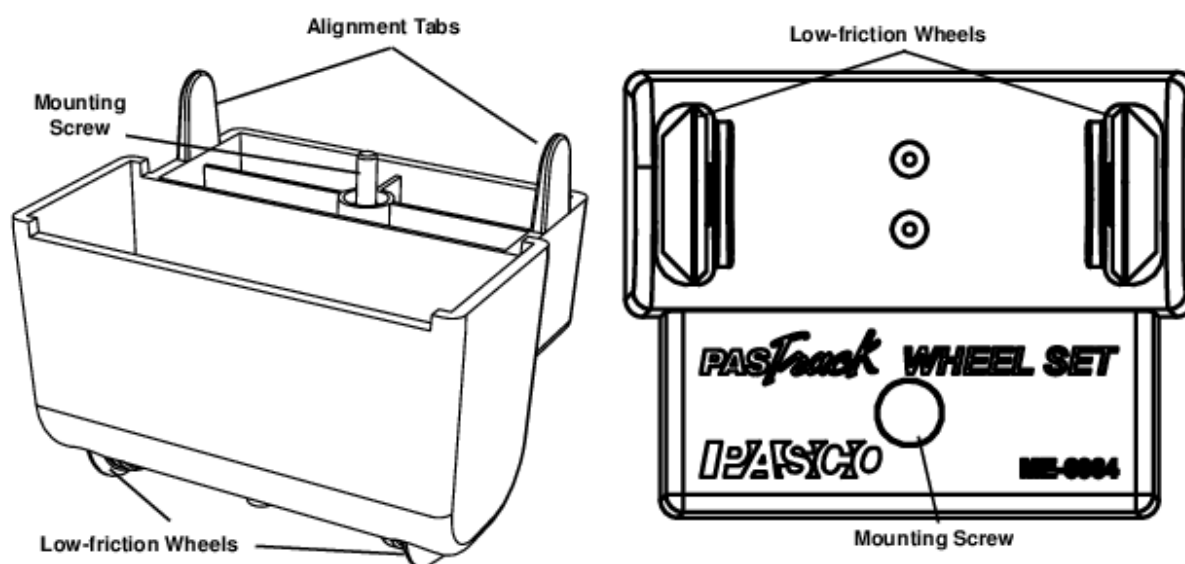

Introduction

The PAStack Wheel Set consists of two wheel enclosures that mount on the bottom of any PAStack. Once the wheel set is mounted on the bottom of a PAStack, the PAStack with wheels can be used to help students better understand frames of reference. For example, a cart runs on top of the PAStack with wheels as the PAStack itself moves. Using visual observation or motion sensors, students can compare the motion of the cart relative to the moving PAStack and relative to the “stationary” lab frame.

The PAStack with wheels can be used on any flat surface such as a tabletop or floor. It can also be used with a dynamics track, which reduces friction and is easily leveled or inclined. The PAStack with wheels is compatible with other PASCO carts, including motorized carts and fan carts.

Assembly

Each wheel enclosure has alignment tabs and a mounting screw. The alignment tabs are designed to fit into similarly shaped notches on both ends of the PAStack approximately 11 cm from each end.

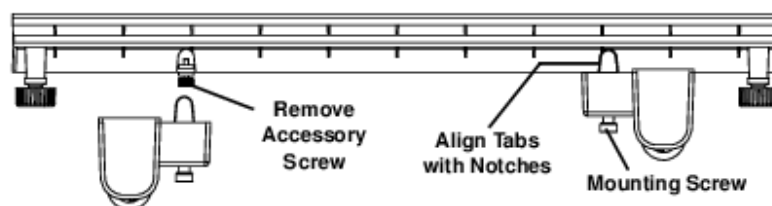

Remove the accessory screw from the threaded hole on the underside of the PAStack between the notches. Align the tabs of the PAStack Wheel Set with the notches, and tighten the mounting screw into the threaded hole to hold the wheel set in place against the bottom of the PAStack.

Suggested Activities

The experiments and demonstrations described in this manual can be done with the PAStack with wheels and other equipment listed on page 2. To add motion sensors to any of the activities, use the setup detailed in Activity 1: Relative Velocity.

Suggested Equipment	Part Number
PAStack with Wheels	Any PAStack plus the ME-6964
Stationary Track	part of any PASCO dynamics system
Dynamics Cart	ME-6951, ME-6950, ME-9430, or ME-9454
Motorized Cart	ME-9781
Time Pulse Accessory	ME-9496
Fan Cart or Fan Accessory	ME-9485 or ME-9491
Sail	Part of ME-9485, or use a piece of cardboard
Compact Cart Mass (250 g)	ME-6755 or similar
Rotational Inertia Set	ME-9774
Motion Sensors (qty. 2)	CI-6742 or PS-2103

Some of these activities also call for stands or blocks to position sensors and incline the track.

Activity 1: Relative Velocity

In this experiment, you will use two motion sensors to measure the velocities of the PAStack with wheels and a motorized cart in the lab reference frame. From these measurements, you will calculate the velocity of the cart in the PAStack with wheel's reference frame.

Equipment Setup



1. Set up two motion sensors as pictured to measure the velocities of the motorized cart and PAStack with wheels

Note that the motion sensor is mounted to allow the PAStack with wheels to pass under it. The sensor's position and angle are adjusted so it detects only the cart, not the PAStack with wheels. (The support piece in the picture is the CI-6692)

Dynamics Track Mount; a similar arrangement can be achieved with a rod stand, right-angle clamp, and horizontal support rod.)

2. Plug the Time Pulse Accessory into the EXT. INPUT jack on the Motorized Cart.
3. Set the switch on the cart to ON (Batt.), and turn speed knob to maximum (full clockwise).
4. Set the rotary switch on the Time Pulse Accessory to position 3, the variable-time setting.
5. Place the cart at one end of the PAStack with wheels and press the START button on the Time Pulse Accessory; after a two second delay the cart will drive for a few seconds and stop automatically. Adjust the variable-time knob so that the cart drives nearly the full length of the PAStack with wheels without falling off the end. (It is not necessary to let the PAStack with wheels move freely for this step.)
6. Set the sample rates of both sensors to 20 Hz. Record some trial data runs and adjust the positions and angles of the sensors to get clear position and velocity data.



Calculations Setup

For more information about creating calculations in DataStudio, click the Calculate button, then press F1 (Windows) or the Help key (Mac).

1. Since the sensors are facing in opposite directions, it is necessary to create a calculation that reverses the velocity measurement of the right-hand sensor; that way both sensors will register movement from left to right as positive. In DataStudio, create the calculation

$$V_{\text{track}} = -V$$

where V is the measured velocity.

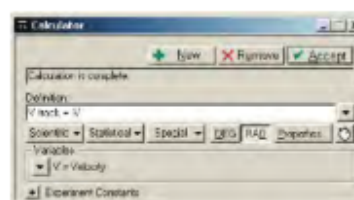

2. Create a second calculation for the velocity of the cart relative to the PAStack with wheels:

$$V_{\text{rel}} = V_{\text{cart}} - V_{\text{track}}$$

where V_{cart} is the measurement made by the left-hand sensor and V_{track} is the previous calculation.

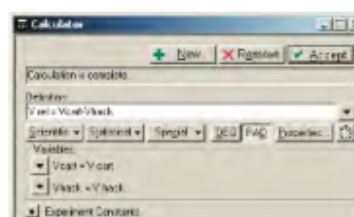

3. (This step is optional.) If you plan to use this arrangement of sensors for other experiments in which you will compare the positions of the cart and PAStack with wheels, create a calculation to transform the position measurement made by the right-hand sensor:

$$x_{\text{track}} = 0.5 - x_{\text{measured}}$$

where x_{measured} is the measurement made directly by the right-hand sensor. The number 0.5 is the difference (in meters) between the length of the PAStack with wheels and the distance between the sensors, which may be different in your setup. This calculation will make the readings from both sensor identical when the back of the cart is even with the left end of the PAStack with wheels.

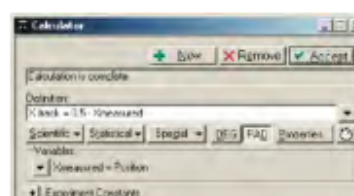

Procedure

Record data as the cart runs from left to right across the PAStack with wheels, which is free to move on the stationary track.

Analysis

1. Look at a graph of v_{rel} versus time. Note that it takes a short time for the motorized cart to get up to speed, then it travels at a constant velocity relative to the PAStack with wheels.
2. Compare v_{rel} to v_{cart} . Why is the cart's velocity higher in the PAStack with wheels' reference frame than in the lab reference frame?
3. Record another data run, but this time hold the PAStack with wheels so it does not move. Compare v_{cart} from this run to v_{rel} from the first run. Why are they the same?

Further Study

Clip a motion sensor to the end of the PAStack with wheels as pictured. In this configuration, the sensor makes a direct measurement of the cart's velocity in the PAStack with wheels' reference frame.

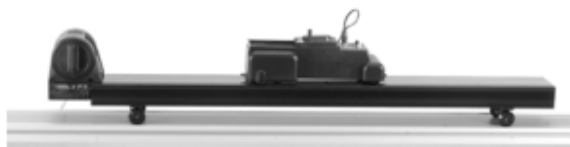

Hold the sensor's cord so that it does not prevent the PAStack with wheels from moving freely. Record data with this setup as the cart runs across the PAStack with wheels.

How does this direct measurement of v_{rel} compare to the original measurement?

Activity 2: Center of Mass

In this experiment, the motorized cart will run the length of the PAStack with wheels and stop automatically while the PAStack with wheels is free to move on a stationary track. You will measure the initial and final positions of both objects and calculate how the center of mass of the cart-track system changes.

Setup

To simplify the theory behind this experiment, the cart and PAStack with wheels should be considered an isolated system. To make this possible, use the following steps to incline the stationary track so that a component of the gravitational force cancels the frictional force between the PAStack with wheels and the stationary track.

1. Follow steps 2 through 5 on page 3 to connect and adjust the Time Pulse Accessory and motorized cart.

2. Level the stationary track.

3. Place the PAStack with wheels on the stationary track and place the cart at the left end of the PAStack with wheels. Press START on the Time Pulse Accessory and allow the cart to drive across the track from left to right as the track moves in the opposite direction. Note that when the cart stops running, the cart-track system continues to move to the right. The force that caused this movement was the friction between the PAStack with wheels and the stationary track.



4. Raise the right end of the stationary track slightly and repeat step 3. The cart-track system should now move to the right slower after the cart stops running. Adjust the incline of the track and repeat step 3 until the cart-track system stops when the cart stops running.

You should find that cart-track system remains stationary if you hold it and let go very carefully (because static friction is higher than kinetic friction), and it will travel at a constant velocity if you nudge it to left (because the component of gravity parallel to the track cancels the friction).¹

Procedure

1. Place the PAStack with wheels on the stationary track and place the cart at the left end of the PAStack with wheels. Using tape, mark:
 - the position of the cart on the PAStack with wheels,
 - the position of the cart on the stationary track, and
 - the position of the PAStack with wheels on the stationary track.
2. Press START on the Time Pulse Accessory and allow the cart to drive across the track from left to right as the track moves in the opposite direction.
3. After the cart stops, measure:
 - $\Delta x_{\text{cart-track}}$, the displacement of the cart on the PAStack with wheels;
 - Δx_{cart} , the displacement of the cart on the stationary track;
 - Δx_{track} , the displacement of the PAStack with wheels on the stationary track.

Analysis

1. What is the relationship between $\Delta x_{\text{cart-track}}$, Δx_{cart} , and Δx_{track} ?
(Hint: do Δx_{cart} and Δx_{track} have the same sign or opposite signs? How should they be combined to equal $\Delta x_{\text{cart-track}}$?)
2. The change in position of the center of mass of the cart-track system is

$$\Delta x_{\text{cm}} = \frac{1}{M}(m_{\text{cart}}\Delta x_{\text{cart}} + m_{\text{track}}\Delta x_{\text{track}})$$

where M is the mass of the system, m_{cart} is the mass of the cart, and m_{track} is the mass of the PAStack with wheels. Measure the masses and calculate Δx_{cm} . Did the system's center of mass change significantly?

3. Add a 250 g mass to the cart and repeat the experiment. Move the mass from the cart to the track (as pictured) and repeat the experiment again.

In the three cases, what variables change? What variables do not change significantly?

¹Another way to counteract friction is to attach a small mass hanging on a string over a pulley. Adjust the mass so that the system stops when the cart stops running, or use a photogate to monitor the speed of the pulley, and adjust the mass so that it moves at a constant velocity when you nudge the track.

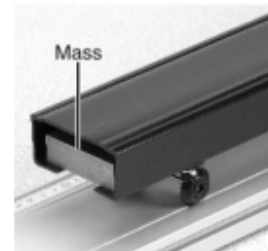
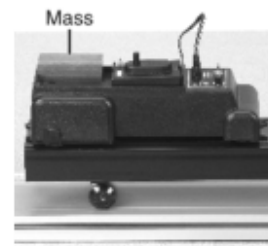

Activity 3: Fan Cart

Use this demonstration to compare the behavior of the fan cart to that of the motorized cart in the previous activities. Before starting the fan cart each time, predict how the fan cart and PAStack with wheels will move relative to the stationary track and to each other.

1. Place the PAStack with wheels on a level stationary track.
2. Place a fan cart on the PAStack with wheels. Turn on the fan.² What happens?
3. Attach a sail to the PAStack with wheels so the air from the fan blows onto the sail.³ Now what happens?

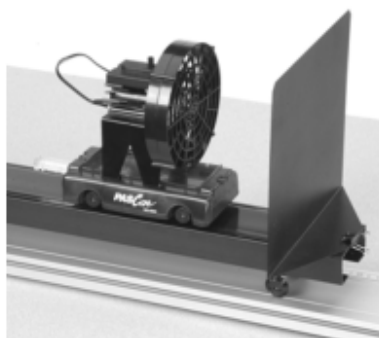

²If you have a Time Pulse Accessory, use it to make the fan run for a second or two before stopping.

³The picture shows the sail included with Fan Cart model ME-9485 attached with a binder clip. You can also use a piece of cardboard.

Activity 4: The Slingshot Effect

In an elastic collision between a moving object and a much more massive stationary object (a tennis ball bouncing off a wall, for instance), the speed of the smaller object after the collision is equal to its speed before. The interaction that occurs when a space probe “slingshots” around a planet can be thought of as a similar elastic collision. How do engineers use this technique to increase the speed of a space probe? (Hint: consider the interaction in the planet’s frame of reference and in the Earth’s frame of reference.)

In this experiment, you will observe an elastic collision between a “planet” (the PAStack with wheels) and a “space probe” (a freely moving cart).

Setup

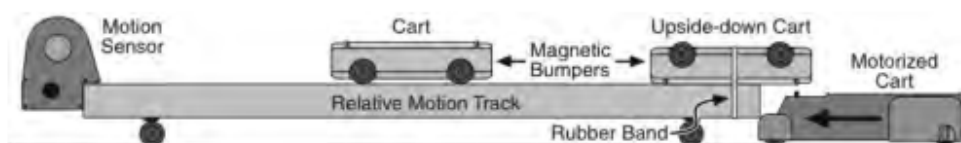

1. Turn a dynamics cart upside down and use a rubber band secure it at one end of the PAStack with wheels, with the magnet-equipped end of the cart pointing toward the center. This cart will be the bumper that the other cart collides with.
2. Place the PAStack with wheels on a 2.2 m dynamics track, on a long tabletop, or on the floor.
3. Position a motorized cart, as pictured, to push the PAStack with wheels.
4. Place the other dynamics cart right-side up on the PAStack with wheels with the magnet end pointing toward the upside-down cart.

- Attach a motion sensor to the end of the PASTrack with wheels to record the velocity of the cart relative to the PASTrack with wheels.

Procedure

Start data collection, then start the motorized cart and observe what happens.

Analysis

- Before looking at the motion-sensor data, consider the motion of the cart in the lab reference frame. Did the cart's speed after the collision appear to be greater than, less than, or equal to its speed before the collision?
- Now consider the motion of the cart as measured by the motion sensor. In the sensor's reference frame, was the cart's speed after the collision greater than, less than, or equal to its speed before the collision?

Activity 5: Inclined Plane

When you release the PASTrack with wheels on an inclined plane, it undergoes constant acceleration. When you hold the PASTrack with wheels still and release a dynamics cart on top of it, the cart undergoes the same constant acceleration. What happens when both the PASTrack with wheels and dynamics cart are released together?

- Stack a dynamics cart on the PASTrack with wheels on an inclined stationary track (as pictured), but don't release them yet.



- Predict how the cart will move relative to the PASTrack with wheels *and* relative to the stationary track.
- Release them. Was your prediction correct?
- For comparison, stack the cart on the PASTrack with wheels on a *level* stationary track. Predict what will happen when you pull the PASTrack with wheels so that it accelerates. Try it. How does the cart move relative to the stationary track? How does it move relative to the PASTrack with wheels?
- Why does the system behave differently when the acceleration of the PASTrack with wheels is caused by your hand compared to when the acceleration is caused by gravity?

Activity 6: Rotational Inertia

- Stack a solid disk and a ring on the PASTrack with wheels on a level stationary track. Predict what will happen when you pull the PASTrack with wheels so that it accelerates.

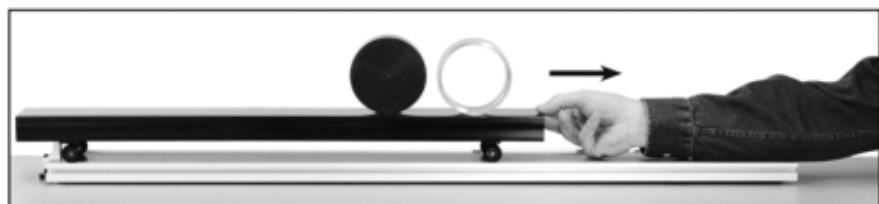

Try it. How do the disk and ring move relative to each other? How do they move

relative to the stationary track? How do they move relative to the PAStack with wheels?

- Incline the stationary track. Place the disk and ring on the PAStack with wheels and hold them on the stationary track. Predict what will happen when you release the disk, ring, and PAStack with wheels all together.
- Release them. How do the disk and ring move relative to each other? How do they move relative to the stationary track? How do they move relative to the PAStack with wheels?
- Why does the system behave differently when the acceleration of the PAStack with wheels is caused by your hand compared to when the acceleration is caused by gravity?

Notes and Sample Data

Activity 1: Relative Velocity

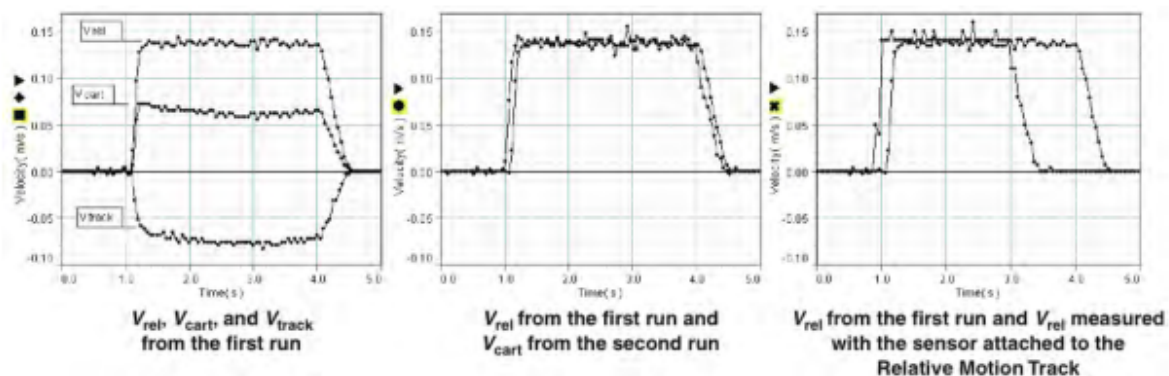

In the first run (left), V_{cart} was positive, V_{track} was negative, and V_{rel} was equal to their difference.

When the PAStack with wheels was held still (center), V_{cart} was equal to V_{rel} from the original data run.

The direct measurement of V_{rel} made with the sensor attached to the PAStack with wheels (right), was also equal to V_{rel} from the first run. Note that the cart was adjusted to run for slightly less time since it had to start 15 cm away from the sensor.

Activity 2: Center of Mass

As shown in this graph (acquired using two motion sensors), the distances traveled by the PAStack with wheels and the motorized cart are different, but the center of mass of the cart-track system remains nearly stationary.

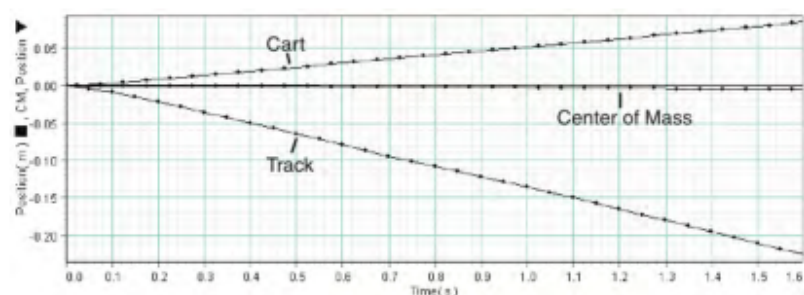

Activity 3: Fan Cart

Without the sail, the fan cart moves and the PAStack with wheels remains stationary. Unlike in the experiment with the motorized cart, the center of mass of the cart-track system does not remain constant because this system is not isolated; the fan cart interacts with the air surrounding the apparatus.

When the sail is attached to the PAStack with wheels, the cart and PAStack with wheels move in opposite directions.

Activity 4: The Slingshot Effect

The cart was visually observed to be nearly stationary (relative to the observer) before the collision and moving to the left faster than the PAStack with wheels after the collision. The data (right), collected by a motion sensor attached to the PAStack with wheels, show that the speeds before and after the collision were approximately equal.

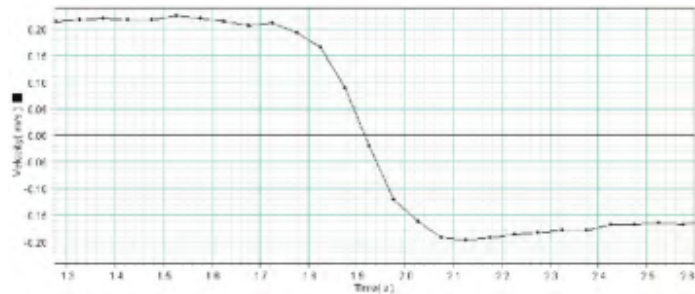

Activity 5: Inclined Plane

When the cart and PAStack with wheels are released together on the inclined plane, the cart does not move relative to the PAStack with wheels; both accelerate at the same rate. When the level PAStack with wheels is accelerated by hand, the cart remains stationary in the lab frame.

Activity 6: Rotational Inertia

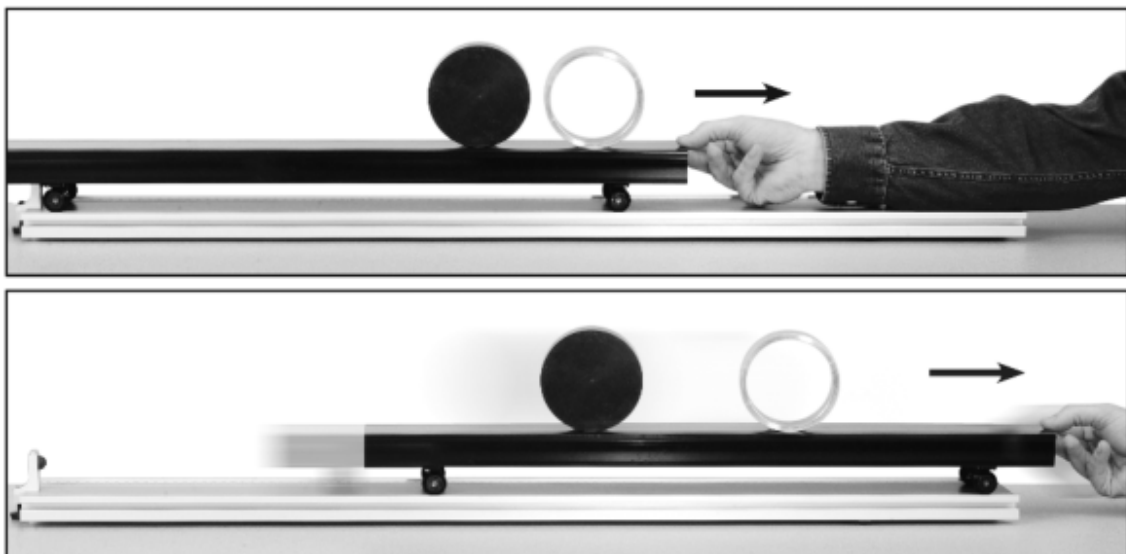

When the PAStack with wheels is accelerated by hand, the disk and ring both move to the right, but the ring moves farther.

When the disk, ring, and PAStack with wheels are all released on an inclined plane, they all accelerate at the same rate. Since the round objects do not move relative to the PAStack with wheels on which they are resting, they do roll and their respective rotational inertias are not important.

Maintenance and Replacement Parts

The PAStack with wheels is not designed to withstand abuse such as being dropped or stood on. Excess weight or shock may cause damage.

If it becomes necessary to replace the wheels, use the PAScar/GOcar Replacement Axles (ME-6957, 4-pack), which consist of wheels and axles.

Keeps the wheel bearings away from sources of dust, such as chalk. If the bearings become contaminated with dust, clear them with compressed air.

Specifications

Approximate Dimensions (L×W×H)	6.2 × 8.2 × 5.4 cm
Mass (each)	Approximately 0.055 kg
Compatible Equipment	Other PASCO carts and tracks