

**Instruction Sheet
for the PASCO
Models ME-9780
and ME-9781**

MOTORIZED CART AND VARIABLE SPEED MOTORIZED CART

**ME-9780
Motorized Cart**

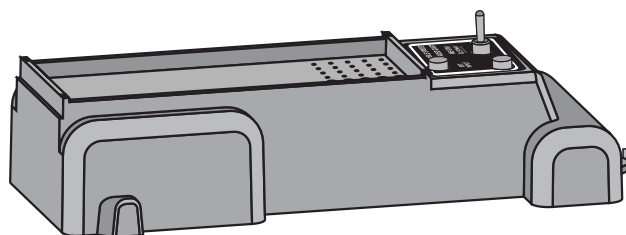
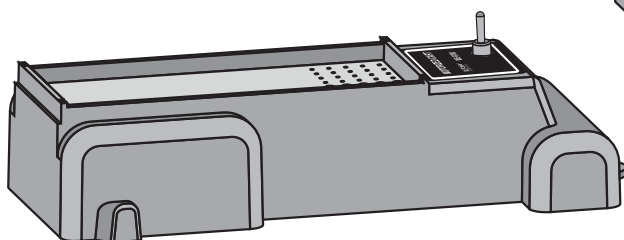

**ME-9781
Variable Speed
Motorized Cart**

Introduction

The PASCO ME-9780 Motorized Cart and ME-9781 Variable Speed Motorized Cart incorporate many features of Dynamics Carts including the precision bearing wheels and mass tray, and have motorized rear wheels geared to operate at constant velocity.

The speed of the ME-9781 Variable Speed Motorized Cart can be varied manually using the variable speed control, or varied automatically and remotely using voltage output from the Signal Generator of *ScienceWorkshop* and the Power Amplifier.

These features expand the scope of experiments possible with the PASCO Dynamics System. By powering the Variable Speed Motorized Cart with the Signal Generator and Power Amplifier, the physical manifestation of several different signal wave forms can be demonstrated.

© 1998 PASCO scientific

Equipment

INCLUDED

- Motorized Cart or Variable Speed Motorized Cart
- 1.8 meter cable with 3.5 mm phone plug and two tinned ends suitable for connection with binding posts (variable speed model only)

ADDITIONAL REQUIRED

- 2 C-type alkaline batteries (ME-9780)
- 4 C-type alkaline batteries (ME-9781)

ADDITIONAL SUGGESTED

- ME-9429A Introductory Dynamics System
- ME-9496 Time Pulse Accessory
- CI-6552A Power Amplifier
- ME-9486 Ballistic Cart Accessory
- CI-6529 or CI-6742 Motion Sensor
- CI-6537 Force Sensor
- CI-6538 Rotary Motion Sensor and ME-6569 RMS/IDS Kit
- *Science Workshop* software and interface (500 series, or 700 series (Variable Speed Motorized Cart only)

Specifications

	Variable Speed Motorized Cart (ME-9781)	Motorized Cart (ME-9780)
Regulated Voltage	Yes	No
Variable Speed	Yes (approx. 0.8–2.5 m/s)	No (approx. 1.5 m/s)
Battery Power	Yes (4 “C” cells)	Yes (2 “C” cells)
External Power Input Jack*	Yes	No
On/Off Switch	Yes	Yes
Battery Life (Alkaline)	6 hrs. or 5 km	6 hrs. or 2 km

*The external power input jack accepts the included 3.5 mm phone plug, and allows connection to:

- a DC Power Supply (such as the Pasco SE-9720 18 VDC, 5A Power Supply)
- CI-6552A Power Amplifier
- ME-9496 Time Pulse Accessory



Caution: Never supply the Variable Speed Motorized Cart with external source voltages greater than ± 6 volts.

Note: An in-wall DC power converter (“brick”) will not supply the necessary current to operate the Variable Speed Motorized Cart for most experiments.

Operation

Battery Installation

Install the C-type alkaline batteries (not included) in the compartment that is accessed from the bottom of the cart.

Manual On/Off

Start and stop the cart manually using the ON/OFF switch.

Speed Adjustments

For the Variable Speed Motorized Cart only, adjust the speed manually using the variable speed control knob.

Remote Control through *Science Workshop’s* Signal Generator (Variable Speed Motorized Cart only)

1. Switch the voltage input to External with the ON/OFF/EXT INPUT switch. (The power from the battery will be cut off, and the cart will receive power from the external source.)

2. Connect the Variable Speed Cart to a CI-6552A Power Amplifier with the supplied cable, and connect the Power Amplifier to the 700 series *Science Workshop* Interface.
3. Start the *Science Workshop* program and open the Signal Generator window.
4. In the Signal Generator window, choose and adjust the signal you want to output.
5. Click the ON button in the Signal Generator window to start outputting the signal.
6. Click the OFF button in the Signal Generator window to stop outputting the signal.

Determining the position, velocity, or acceleration of the Motorized Cart

For determinations of position, velocity, or speed that require little setup time, use *Science Workshop* and a Motion Sensor. For more precise measurements, use a Rotary Motion Sensor and the RMS/IDS Adapter.

On/Off by Time Pulse Accessory (Variable Speed Motorized Cart only)

1. Mount the Pasco ME-9496 Time Pulse Accessory on the Variable Speed Motorized Cart by inserting the studs on the bottom of the Time Pulse Accessory into the holes in the top of the cart.

Note: Be sure the cart switch is in the *OFF* position before inserting the plug.

2. Plug the 3.5 mm phone plug into the external jack of the cart (Figure 1).

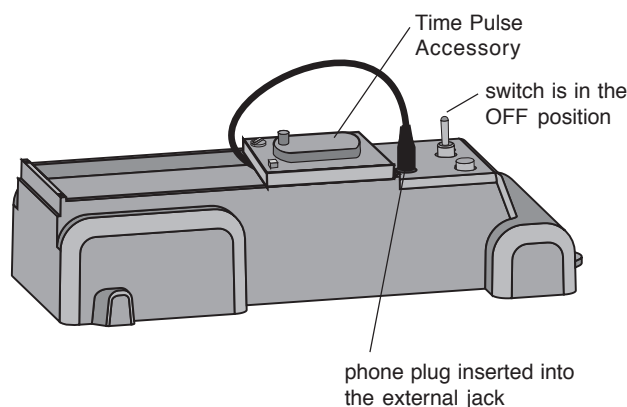

Figure 1
Mounting the Time Pulse Accessory on the Variable Speed Cart

3. Test the Time Pulse Accessory by switching the time switch to 1 second. Turn the Variable Speed Motorized Cart switch *ON* and press the *START* switch on the Time Pulse Accessory. After a two second delay, the device should switch *ON* for one second, then switch *OFF*.

Note: The other delays may be tested in the same manner. Remember to turn the Variable Speed Motorized Cart switch *OFF* when testing is completed.

4. Set the time switch to the desired delay time according to the legend on the case and press *START*.

Note: When using the variable control on the Time Pulse Accessory, the time will be roughly proportional to the mechanical setting of the control, from less than one, to about seven seconds.

Suggested Activities

Relative Motion

Use a piece of paper on the floor to simulate the motion of a river, and simulate the relative motion of a boat crossing the river by moving the piece of paper while the cart is traveling over it (Figure 2).

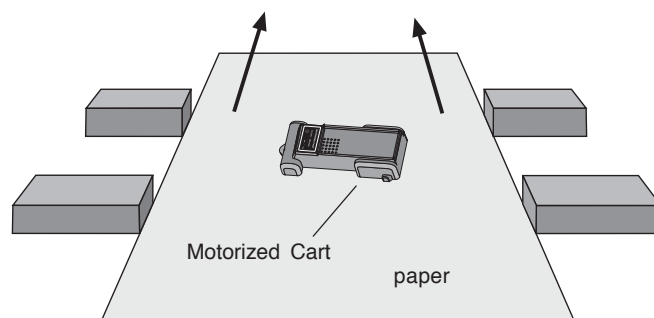

Figure 2
Motorized Cart set up to demonstrate the concept of relative motion

Vectors with Relative Motion

Explore vectors by mounting a Motion Sensor at an angle on the Motorized Cart. Place the track at an angle to the wall and position the Motion Sensor square with the wall (at a 90° angle) (Figure 3).

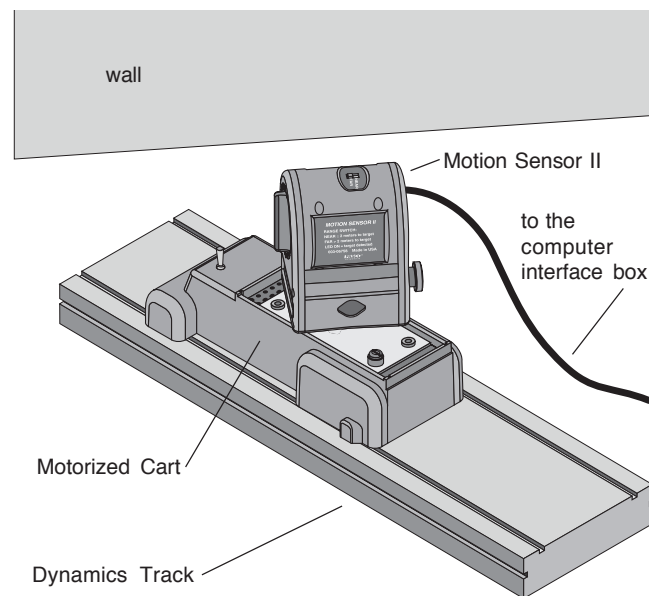

Figure 3
Motorized Cart and the Pasco CI-6742 Motion Sensor II on a Dynamics Track, oriented for exploring vectors with relative motion

The Motion Sensor will record the relative velocity of the Motion Sensor with respect to the wall. Next, orient the track so it is perpendicular to the wall, and repeat the run. The velocity measured by the Motion Sensor is now the full velocity. In *Science Workshop*, plot both runs on a Graph display of velocity vs. time.

Independence of Vertical and Horizontal Motion

Mount a Ballistic Cart Accessory onto the Motorized Cart and fire it while the cart is moving (Figure 4.)

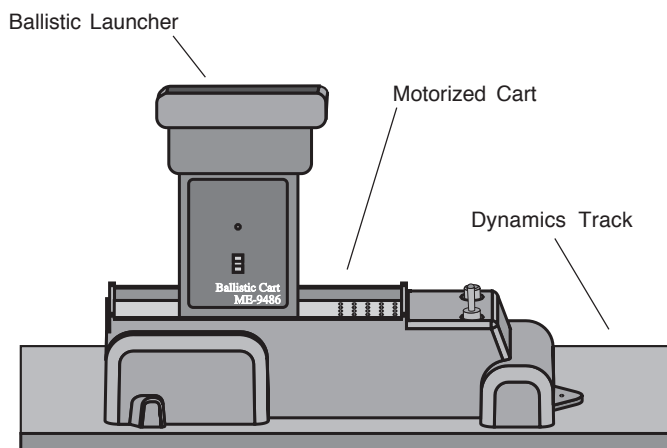

Figure 4
The Pasco ME-9486 Ballistic Cart Accessory mounted on the Motorized Cart to demonstrate the independence of Vertical and Horizontal Motion

Angle of Incline vs. Efficiency (Constant Force)

Explore the effect of the angle of incline of a Dynamics Track on the efficiency of the Motorized Cart. Measure the speed of the cart at various angles of incline using a Motion Sensor or Rotary Motion Sensor and RMS/IDS Adapter. Add a second Rotary Motion Sensor and the Chaos

Accessory to monitor the angle of the track. (See Figure 5).

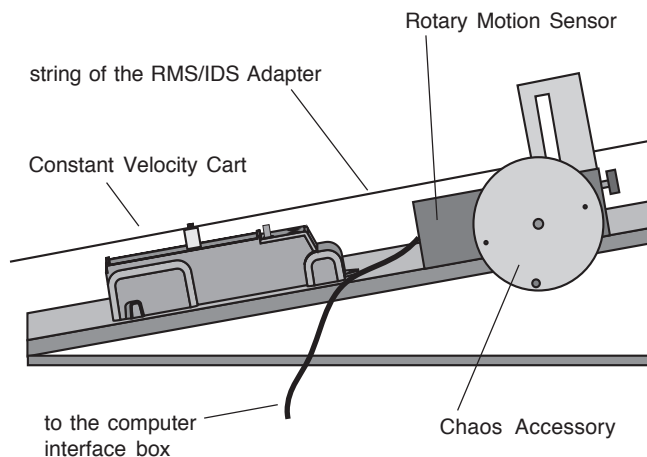

Figure 5
Setup to explore the effect of the angle on incline on efficiency, using *Science Workshop* and accessories

Plot the % efficiency vs. angle of incline, where % efficiency is:

$$\% \text{ efficiency} = \frac{\text{mechanical power}}{\text{electrical power}} \times 100$$

See Figure 6 for an example of typical experimental results.

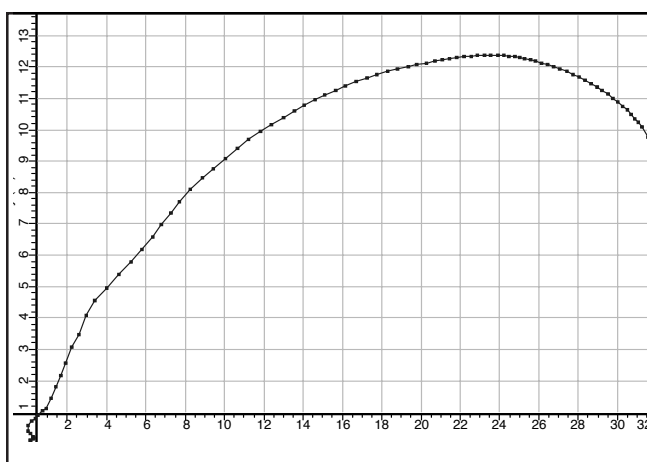

Figure 6
Typical plot in *Science Workshop* of % efficiency vs. angle of incline

Note: Data has been smoothed in *Science Workshop*

Constant Acceleration vs. Constant Velocity

Compare the effect of a constant acceleration for measured time vs. constant velocity for a measured time. Use the Time Pulse Accessory to supply power for a constant time to the Motorized Cart and compare its motion to that of a Fan Cart that has been supplied with power for the same time period (Figure 7).

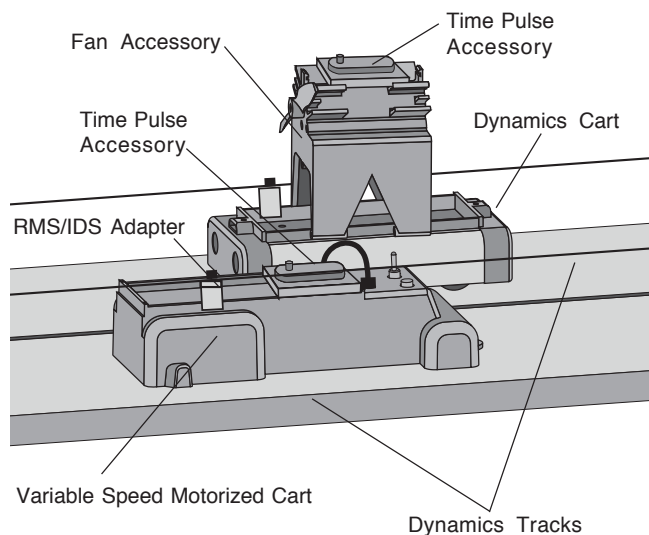

Figure 7

Setup for comparing constant acceleration with constant velocity using *Science Workshop* and accessories

Track the position vs. time of the Motorized Cart and the Fan Cart using two Rotary Motion Sensors and IDS/RMS adapters with *Science Workshop* (See Figure 8 for typical experimental results).

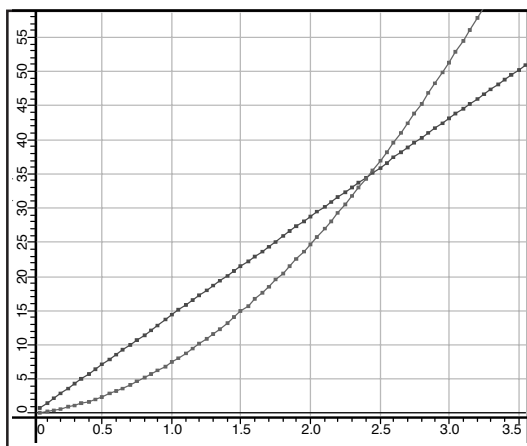

Figure 8

Typical results of plotting a comparison of position vs. time for constant velocity and constant acceleration

Alternatively, collect data on the Motorized Cart using the Rotary Motion Sensor and IDS/RMS adaptor, and then collect data on the Fan Cart using an Time Pulse of the same time period. In this manner, both runs can be plotted on the same Graph display, clearly showing the difference in position vs. time for a plot of constant velocity and a plot of constant acceleration.

Variable Force vs. Efficiency (Constant Angle of Incline) (Variable Speed Motorized Cart only)

Explore the relationship between varying force and efficiency when the Motorized Cart is climbing a track inclined at 30°. Use the Rotary Motion Sensor and the IDS/RMS Adapter to monitor the position of the cart (Figure 9).

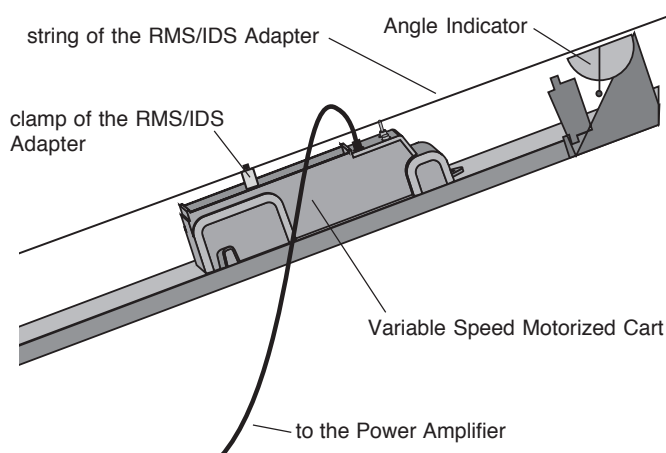

Figure 9

Setup for exploring the relationship between varying force and efficiency using *Science Workshop* and accessories

Vary the voltage supplied to the Motorized Cart with the “ramp down” signal from the Signal Generator in *Science Workshop*.

Manifest Different Voltage Wave Forms (Variable Speed Motorized Cart only)

Explore the effect of controlling the Variable Speed Motorized Cart with a variety of wave forms (sine, square, triangle, ramp up, ramp down, positive-only square, positive only ramp up, and positive only ramp down) from *Science Workshop*'s Signal

Generator (700 series only). On a Graph display with two x-axes, plot the voltage and the position of the cart or plot the voltage and the speed vs. time.

Independence of Kinetic Friction and Velocity (Variable Speed Motorized Cart only)

Determine the effect of speed on kinetic friction with a Force Sensor mounted on the Motorized Cart and attached to a mass on a friction block (Figure 10). (The Force Sensor will monitor the kinetic friction).

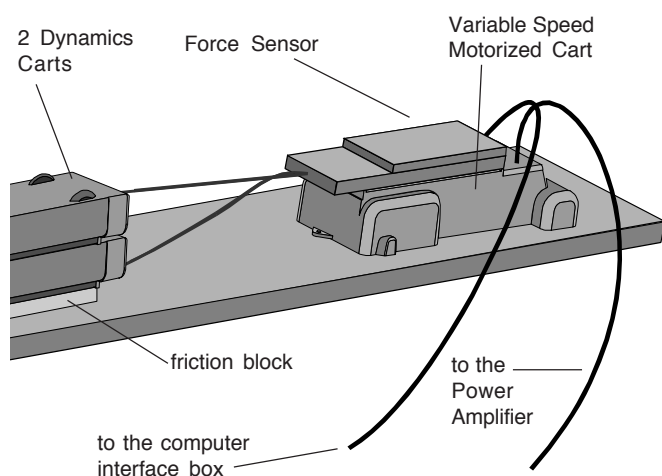

Figure 10
Setup to explore the effect of speed on kinetic friction using *Science Workshop* and accessories

Vary the speed using the “ramp up” function from *Science Workshop*’s Signal Generator. Monitor the velocity of the Motorized Cart with a Motion Sensor.

Note: This instruction sheet was written assuming that the user is familiar with *Science Workshop*. Users can gain familiarity by working through the tutorials provided with *Science Workshop*.

Limited Warranty

PASCO scientific warrants the product to be free from defects in materials and workmanship for a period of one year from the date of shipment to the customer. PASCO will repair or replace, at its option, any part of the product which is deemed to be defective in material or workmanship. The warranty does not cover damage to the product caused by abuse or improper use. Determination of whether a product failure is the result of a manufacturing defect or improper use by the customer shall be made solely by PASCO scientific. Responsibility for the return of equipment for warranty repair belongs to the customer. Equipment must be properly packed to prevent damage and shipped postage or freight prepaid. (Damage caused by improper packing of the equipment for return shipment will not be covered by the warranty.) Shipping costs for returning the equipment after repair will be paid by PASCO scientific.

Address: PASCO scientific
10101 Foothills Blvd.
Roseville, CA 95747-7100

Phone: (916) 786-3800
FAX: (916) 786-8905
e-mail: techsupp@pasco.com
web: www.pasco.com



The exclamation point within an equilateral triangle is intended to alert the user of important operating and safety instructions that will help prevent damage to the equipment or injury to the user.