

**Instruction Manual and
Experiment Guide for
the PASCO scientific
Model OS-9261A, 62 and 63A**

SPEED OF LIGHT APPARATUS

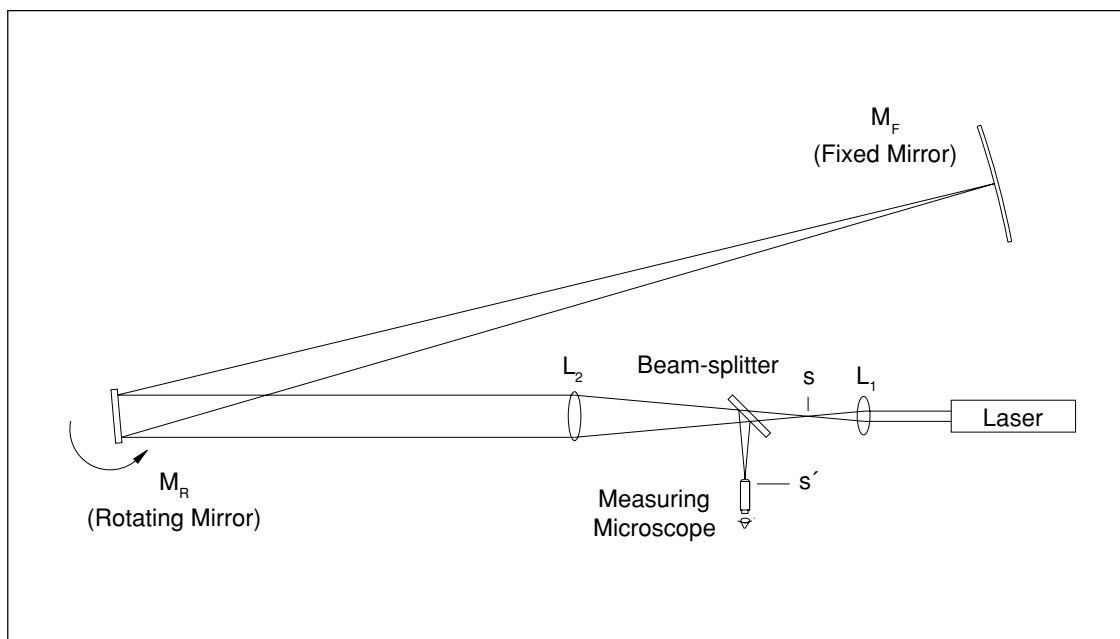

Introduction

The velocity of light in free space is one of the most important and intriguing constants of nature. Whether the light comes from a laser on a desk top or from a star that is hurtling away at fantastic speeds, if you measure the velocity of the light, you measure the same constant value. In more precise terminology, the velocity of light is independent of the relative velocities of the light source and the observer.

Furthermore, as Einstein first presented in his *Special Theory of Relativity*, the speed of light is critically important in some surprising ways. In particular:

1. The velocity of light establishes an upper limit to the velocity that may be imparted to any object.
2. Objects moving near the velocity of light follow a set of physical laws drastically different, not only from Newton's Laws, but from the basic assumptions of human intuition.

With this in mind, it's not surprising that a great deal of time and effort has been invested in measuring the speed of light. Some of the most accurate measurements were made by Albert Michelson between 1926 and 1929 using methods very similar to those you will be using with the PASCO Speed of Light Apparatus. Michelson measured the velocity of light in air to be 2.99712×10^8 m/sec. From this result he deduced the velocity in free space to be 2.99796×10^8 m/sec.

But Michelson was by no means the first to concern himself with this measurement. His work was built on a history of ever-improving methodology.

Measuring the Velocity of Light: History

Galileo

Through much of history, those few who thought to speculate on the velocity of light considered it to be infinite. One of the first to question this assumption was the great Italian physicist Galileo, who suggested a method for actually measuring the speed of light.

The method was simple. Two people, call them A and B, take covered lanterns to the tops of hills that are separated by a distance of about a mile. First A uncovers her lantern. As soon as B sees A's light, she uncovers her own lantern. By measuring the time from when A uncovers her lantern until A sees B's light, then dividing this time by twice the distance between the hill tops, the speed of light can be determined.

However, the speed of light being what it is, and human reaction times being what they are, Galileo was able to determine only that the speed of light was far greater than could be measured using his procedure. Although Galileo was unable to provide even an approximate value for the speed of light, his experiment set the stage for later attempts. It also introduced an important point: to measure great velocities accurately, the measurements must be made over a long distance.

Römer

The first successful measurement of the velocity of light was provided by the Danish astronomer Olaf Römer in 1675. Römer based his measurement on observations of the eclipses of one of the moons of Jupiter. As this moon orbits Jupiter, there is a period of time when Jupiter lies between it and the Earth, and blocks it from view. Römer noticed that the duration of these eclipses was shorter when the Earth was moving toward Jupiter than when the Earth was moving away. He correctly interpreted this phenomena as resulting from the finite speed of light.

Geometrically the moon is always behind Jupiter for the same period of time during each eclipse. Suppose, however, that the Earth is moving away from Jupiter. An astronomer on Earth catches his last glimpse of the moon, not at the instant the moon moves behind Jupiter, but only after the last bit of unblocked light from the moon reaches his eyes. There is a similar delay as the moon moves out from behind Jupiter but, since the Earth has moved

farther away, the light must now travel a longer distance to reach the astronomer. The astronomer therefore sees an eclipse that lasts longer than the actual geometrical eclipse. Similarly, when the Earth is moving toward Jupiter, the astronomer sees an eclipse that lasts a shorter interval of time.

From observations of these eclipses over many years, Römer calculated the speed of light to be 2.1×10^8 m/sec. This value is approximately 1/3 too slow due to an inaccurate knowledge at that time of the distances involved. Nevertheless, Römer's method provided clear evidence that the velocity of light was not infinite, and gave a reasonable estimate of its true value—not bad for 1675.

Fizeau

The French scientist Fizeau, in 1849, developed an ingenious method for measuring the speed of light over terrestrial distances. He used a rapidly revolving cogwheel in front of a light source to deliver the light to a distant mirror in discrete pulses. The mirror reflected these pulses back toward the cogwheel. Depending on the position of the cogwheel when a pulse returned, it would either block the pulse of light or pass it through to an observer.

Fizeau measured the rates of cogwheel rotation that allowed observation of the returning pulses for carefully measured distances between the cogwheel and the mirror. Using this method, Fizeau measured the speed of light to be 3.15×10^8 m/sec. This is within a few percent of the currently accepted value.

Foucault

Foucault improved Fizeau's method, using a rotating mirror instead of a rotating cogwheel. (Since this is the method you will use in this experiment, the details will be discussed in considerable detail in the next section.) As mentioned, Michelson used Foucault's method to produce some remarkably accurate measurements of the velocity of light. The best of these measurements gave a velocity of 2.99774×10^8 m/sec. This may be compared to the presently accepted value of 2.99792458×10^8 m/sec.

The Foucault Method

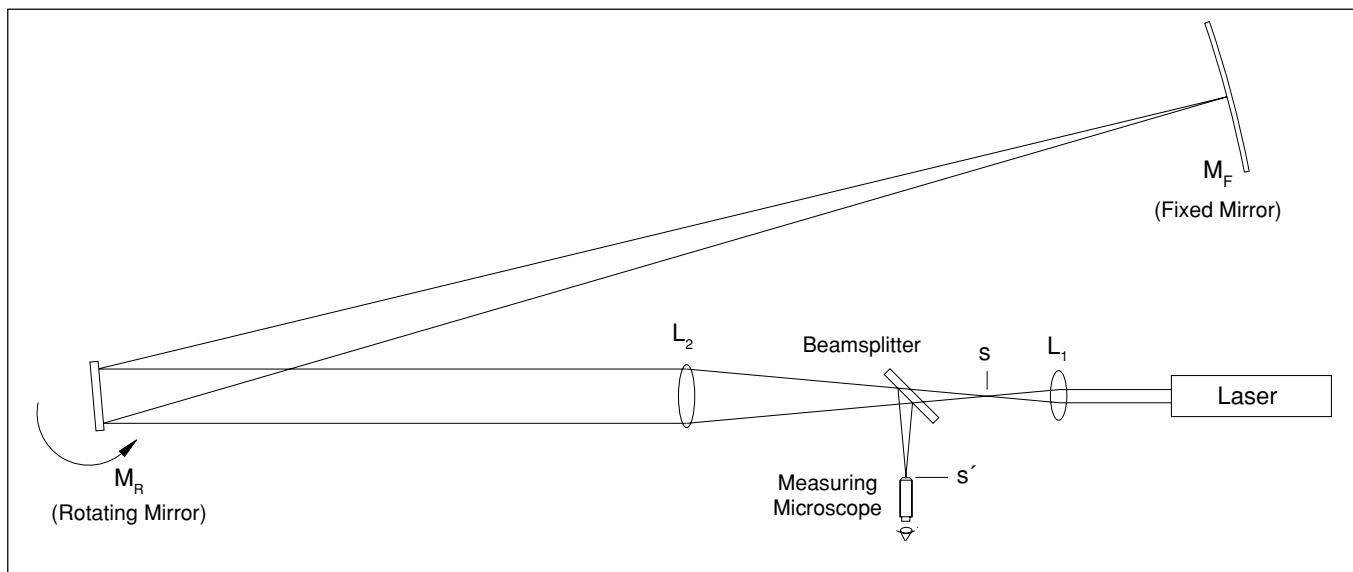

Figure 1: Diagram of the Foucault Method

A Qualitative Description

In this experiment, you will use a method for measuring the speed of light that is basically the same as that developed by Foucault in 1862. A diagram of the experimental setup is shown in Figure 1, above.

With all the equipment properly aligned and with the rotating mirror stationary, the optical path is as follows. The parallel beam of light from the laser is focused to a point image at point s by lens L_1 . Lens L_2 is positioned so that the image point at s is reflected from the rotating mirror M_R , and is focused onto the fixed, spherical mirror M_F . M_F reflects the light back along the same path to again focus the image at point s .

In order that the reflected point image can be viewed through the microscope, a beam splitter is placed in the optical path, so a reflected image of the returning light is also formed at point s' .

Now, suppose M_R is rotated slightly so that the reflected beam strikes M_F at a different point. Because of the spherical shape of M_F , the beam will still be reflected directly back toward M_R . The return image of the source point will still be formed at points s and s' . The only significant difference in rotating M_R by a slight amount is that the point of reflection on M_F changes.

Now imagine that M_R is rotating continuously at a very high speed. In this case, the return image of the source point will no longer be formed at points s and s' . This is because, with M_R rotating, a light pulse that travels from M_R to M_F and back finds M_R at a different angle when it returns than when it was first reflected. As will be shown in the following derivation, by measuring the displacement of the image point caused by the rotation of M_R , the velocity of light can be determined.

A Quantitative Description

In order to use the Foucault method to measure the speed of light, it's necessary to determine a precise relationship between the speed of light and the displacement of the image point. Of course, other variables of the experimental setup also affect the displacement. These include:

- the rate of rotation of M_R
- the distance between M_R and M_F
- the magnification of L_2 , which depends on the focal length of L_2 and also on the distances between L_2 , L_1 , and M_F .

Each of these variables will show up in the final expression that we derive for the speed of light.

To begin the derivation, consider a beam of light leaving the laser. It follows the path described in the qualitative description above. That is, first the beam is focused to a point at s , then reflected from M_R to M_F , and back to M_R . The beam then returns through the beamsplitter, and is refocused to a point at point s' , where it can be viewed through the microscope. This beam of light is reflected from a particular point on M_F . As the first step in the derivation, we must determine how the point of reflection on M_F relates to the rotational angle of M_R .

Figure 2a shows the path of the beam of light, from the laser to M_F , when M_R is at an angle θ . In this case, the angle of incidence of the light path as it strikes M_R is also θ and, since the angle of incidence equals the angle of reflection, the angle between the incident and reflected rays is just 2θ . As shown in the diagram, the pulse of light strikes M_F at a point that we have labeled S .

Figure 2b shows the path of the pulse of light if it leaves the laser at a slightly later time, when M_R is at an angle $\theta_1 = \theta + \Delta\theta$. The angle of incidence is now equal to $\theta_1 = \theta + \Delta\theta$, so that the angle between the incident and reflected rays is just $2\theta_1 = 2(\theta + \Delta\theta)$. This time we label the point where the pulse strikes M_F as S_1 . If we define D as the distance between M_F and M_R , then the distance between S and S_1 can be calculated:

$$S_1 - S = D(2\theta_1 - 2\theta) = D[2(\theta + \Delta\theta) - 2\theta] = 2D\Delta\theta \text{ (EQ1)}$$

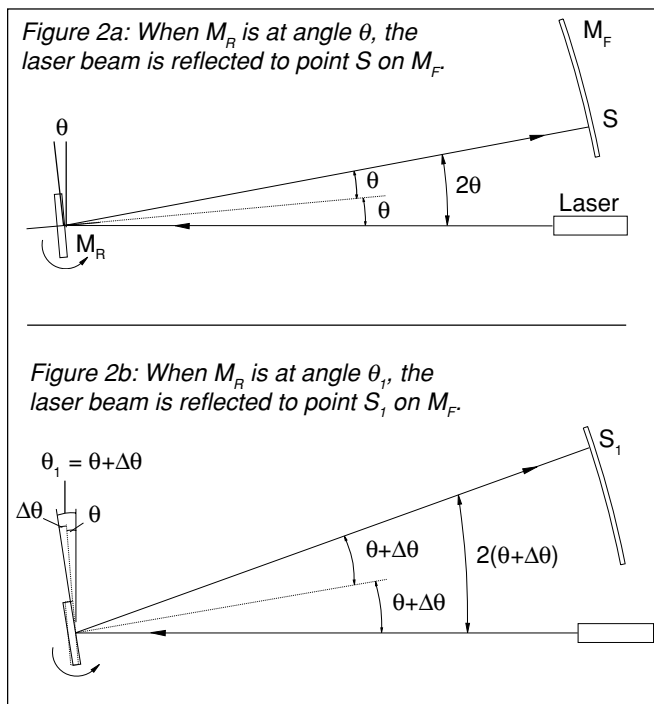

Figure 2 a,b: The Reflection Point on M_F

In the next step in the derivation, it is helpful to think of a single, very quick pulse of light leaving the laser. Suppose M_R is rotating, and this pulse of light strikes M_R when it is at angle θ , as in Figure 2a. The pulse will then be reflected to point S on M_F . However, by the time the pulse returns to M_R , M_R will have rotated to a new angle, say angle θ_1 . If M_R had not been rotating, but had remained stationary, this returning pulse of light would be refocused at point s . Clearly, since M_R is now in a different position, the light pulse will be refocused at a different point. We must now determine where that new point will be.

The situation is very much like that shown in Figure 2b, with one important difference: the beam of light that is returning to M_R is coming from point S on M_F , instead of from point S_1 . To make the situation simpler, it is convenient to remove the confusion of the rotating mirror and the beam splitter by looking at the virtual images of the beam path, as shown in Figure 3.

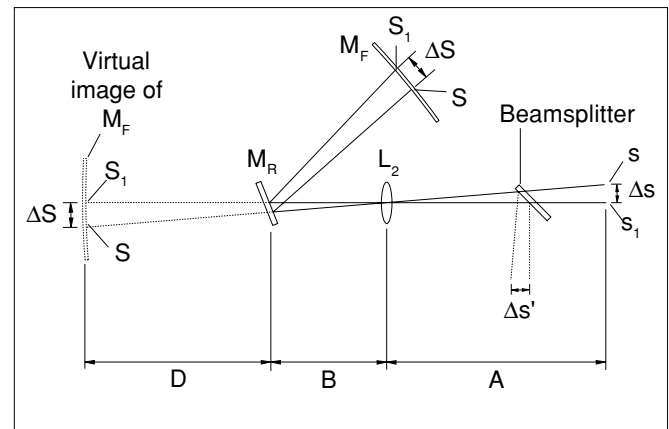

Figure 3: Analyzing the Virtual Images

The critical geometry of the virtual images is the same as for the reflected images. Looking at the virtual images, the problem becomes a simple application of thin lens optics. With M_R at angle θ_1 , point S_1 is on the focal axis of lens L_2 . Point S is in the focal plane of lens L_2 , but it is a distance $\Delta S = S_1 - S$ away from the focal axis. From thin lens theory, we know that an object of height ΔS in the focal plane of L_2 will be focused in the plane of point s with a height of $(-i/o)\Delta S$. Here i and o are the distances of the lens from the image and object, respectively, and the minus sign corresponds to the inversion of the image. As shown in Figure 3, reflection from the beam splitter forms a similar image of the same height.

Therefore, ignoring the minus sign since we aren't concerned that the image is inverted, we can write an expression for the displacement ($\Delta s'$) of the image point:

$$\Delta s' = \Delta s = (i/o)\Delta S = \frac{A}{D+B} \Delta S \quad (\text{EQ2})$$

Combining equations 1 and 2, and noting that $\Delta S = S_1 - S$, the displacement of the image point relates to the initial and secondary positions of M_R by the formula:

$$\Delta s' = \frac{2DA}{D+B} \Delta\theta \quad (\text{EQ3})$$

The angle $\Delta\theta$ depends on the rotational velocity of M_R and on the time it takes the light pulse to travel back and forth between the mirrors M_R and M_F , a distance of $2D$. The equation for this relationship is:

$$(\text{EQ4})$$

where c is the speed of light and ω is the rotational velocity of the mirror in radians per second. ($2D/c$ is the time it takes the light pulse to travel from M_R to M_F and back.)

$\Delta\theta = \frac{2D\omega}{c}$ Using equation 4 to replace $\Delta\theta$ in equation 3 gives:

$$\Delta s' = \frac{4AD^2\omega}{c(D+B)} \quad (\text{EQ5})$$

Equation 5 can be rearranged to provide our final equation for the speed of light:

$$c = \frac{4AD^2\omega}{(D+B)\Delta s'} \quad (\text{EQ6})$$

where:

c = the speed of light

w = the rotational velocity of the rotating mirror (M_R)

A = the distance between lens L_2 and lens L_1 , minus the focal length of L_1

B = the distance between lens L_2 and the rotating mirror (M_R)

D = the distance between the rotating mirror (M_R) and the fixed mirror (M_F)

$\Delta s'$ = the displacement of the image point, as viewed through the microscope. ($\Delta s' = s_1 - s$; where s is the position of the image point when the rotating mirror (M_R) is stationary, and s_1 is the position of the image point when the rotating mirror is rotating with angular velocity ω .)

Equation 6 was derived on the assumption that the image point is the result of a single, short pulse of light from the laser. But, looking back at equations 1-4, the displacement of the image point depends only on the *difference* in the angular position of M_R in the time it takes for the light to travel between the mirrors. The displacement does not depend on the specific mirror angles for any given pulse.

If we think of the continuous laser beam as a series of infinitely small pulses, the image due to each pulse will be displaced by the same amount. All these images displaced by the same amount will, of course, result in a single image. By measuring the displacement of this image, the rate of rotation of M_R , and the relevant distances between components, the speed of light can be measured.

The Equipment

What You Need to Measure the Speed of Light

In order to measure the speed of light as described in this manual, you will need all the items listed below (see Figure 4). If you have an OS-9261 Complete Speed of Light Apparatus, everything is included. If you have the OS-9262 Basic Speed of Light Apparatus or the OS-9263A High Speed Rotating Mirror, you will need additional components, as listed, to make the measurement.

The OS-9261 Complete Speed of Light Apparatus includes:

- OS-9262 Basic Speed of Light Apparatus, which includes:
 - OS-9263A High Speed Rotating Mirror Assembly
 - Fixed Mirror
 - Measuring Microscope

- SE-9367 0.5 mW He-Ne Laser
- OS-9103 One-Meter Optics Bench
- OS-9172 Laser Alignment Bench
- OS-9142 Optics Bench Couplers
- OS-9133 Lens (48 mm FL)
- OS-9135 Lens (252 mm FL)
- OS-9109 Calibrated Polarizers (2)
- OS-9107 Component Holders (3)
- OS-8514 Laser Adapter Kit
- Alignment Jigs (2) – Part Number 648-02230

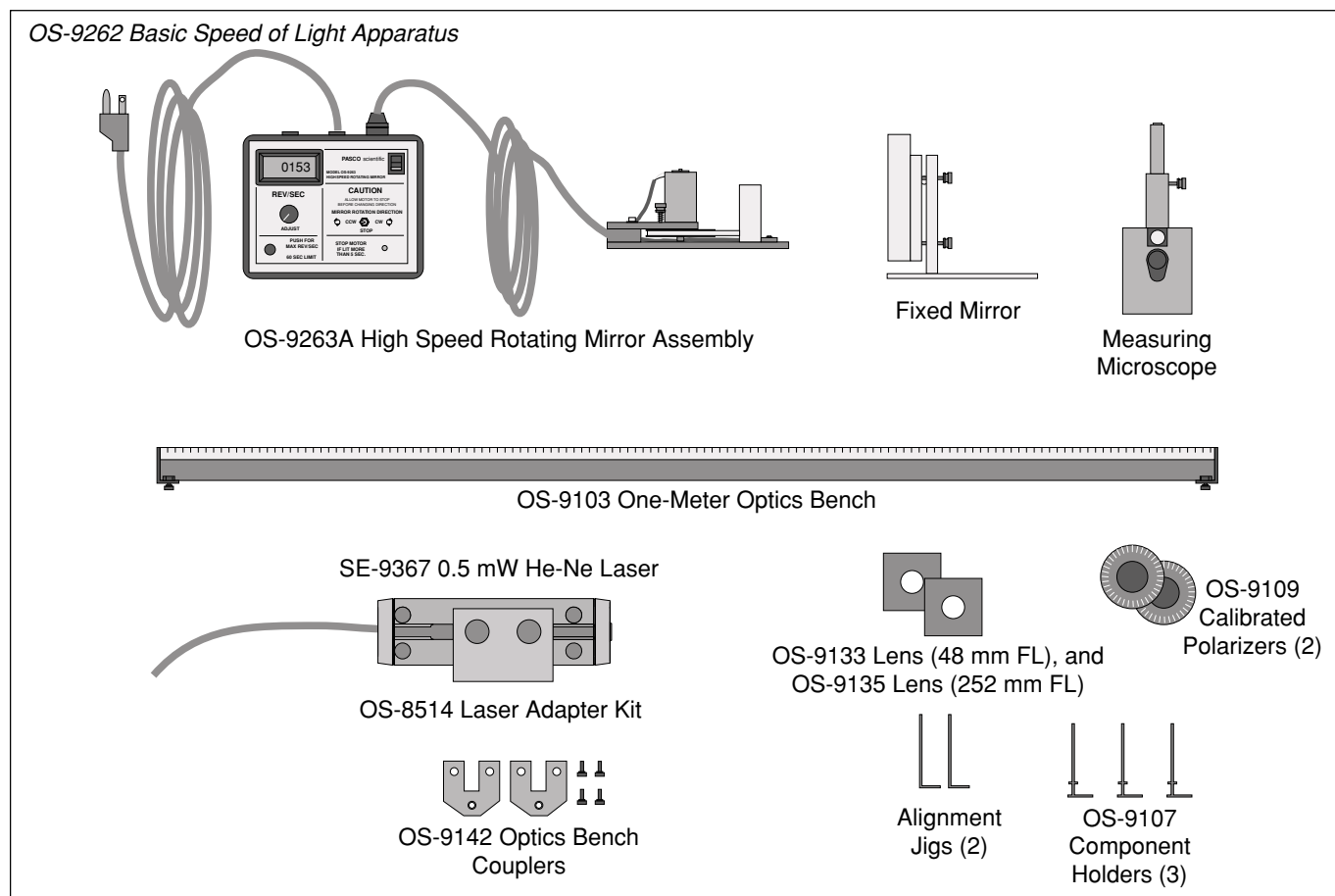

Figure 4: Equipment Included with the OS-9261A Complete Speed of Light Apparatus

About the Equipment

1. High Speed Rotating Mirror Assembly

The High Speed Rotating Mirror comes with its own power supply and digital display. The mirror is flat to within $1/4$ wavelength. It's supported by high speed ball bearings, mounted in a protective housing, and driven by a DC motor with a drive belt. A plastic lock-screw lets you hold the mirror in place during the alignment procedure.

An optical detector and the digital display provide measurements of mirror rotation to within 0.1% or 1 rev/sec. The display and the controls for mirror rotation are on the front panel of the power supply. Rotation is reversible and the rate is continuously variable from 100 to 1,000 rev/sec. In addition, holding down the MAX REV/SEC button will bring the rotation speed quickly to its maximum value at approximately 1,500 rev/sec.

➤ **CAUTION:** Before turning on the motor for the rotating mirror, carefully read the cautionary notices in the section of this manual entitled "Making the Measurement".

2. Measuring Microscope

The 90X microscope is mounted on a micrometer stage for precise measurements of the displacement of the image point. Measurements are most easily made by visually centering the image point on the microscope cross-hairs before and after the displacement. By noting the change in the micrometer setting, the displacement can be resolved to within 0.005 mm.

To focus the cross-hairs, slide the eyepiece up or down in the microscope. To focus the microscope, loosen the lock-screw on the side of the mounting tube and slide the microscope up or down within the tube.

With the lock-screw loosened, the microscope can also be removed from the mounting tube. This can be helpful when you are trying to locate the image point. A piece of tissue paper placed over the tube provides a screen that allows you to view the point without focusing the microscope.

In addition to the microscope and micrometer, the micrometer stage also contains the beamsplitter. The lever on the side of the stage is used to adjust the angle of the beamsplitter. When the lever points directly down, the beamsplitter is at a forty-five degree angle.

3. Fixed Mirror

The Fixed Mirror is a spherical mirror with a radius of curvature of 13.5 meters. It is mounted to a stand and has separate x and y alignment screws.

4. OS-9103 Optics Bench

The 1.0 meter long Optics Bench provides a flat, level surface for aligning the optical components. The bench is equipped with a one meter scale, four leveling screws, and a magnetic top surface. The "fence", a raised edge on the back of the bench, provides a guide for aligning components along the optical axis.

5.) SE-9367 Laser with the OS-9172 Alignment Bench

The 0.5 mW, TEM₀₀ mode, random polarization laser has an output wavelength of 632.8 nm. The Alignment Bench attaches to the Optics Bench for precise, stable positioning of the laser.

6. Alignment Jigs (2)

These jigs mount magnetically to the Optics Bench. Each has a 2 mm diameter hole that is used to align the laser beam.

7. Optical Components

The use of the lenses and polarizers is described in the *Setup and Alignment* section of the manual.

Setup and Alignment

The following alignment procedure is tailored for those using the OS-9261A Complete Speed of Light Apparatus. For those using only some of the components in the complete system, the general procedure is the same, though the details depend on the optical components used.

➤ **IMPORTANT:** Proper alignment is critical, not only for getting good results, but for getting any results at all. Please follow this alignment procedure carefully. *Allow yourself about three hours to do it properly the first time. Once you have set up the equipment a few times, you may find that the alignment summary at the end of this section is a helpful guide.*

For reference as you set up the equipment, Figure 5 shows the approximate positioning of the components with respect to the metric scale on the side of the Optics Bench. The exact placement of each component depends on the position of the Fixed Mirror (M_F) and must be determined by following the steps of the alignment procedure described below.

All component holders, the Measuring Microscope, and the Rotating Mirror Assembly should be mounted flush against the “fence” of the Optics Bench (Figure 6). This will insure that all components are mounted at right angles to the beam axis.

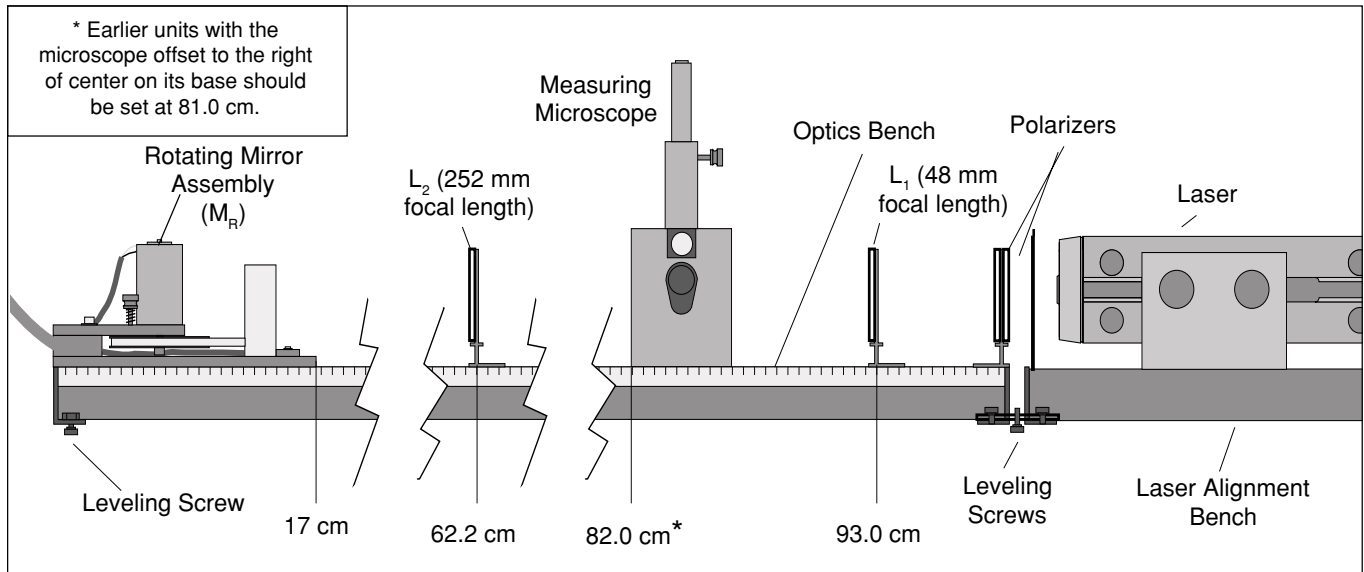

Figure 5: Equipment Alignment

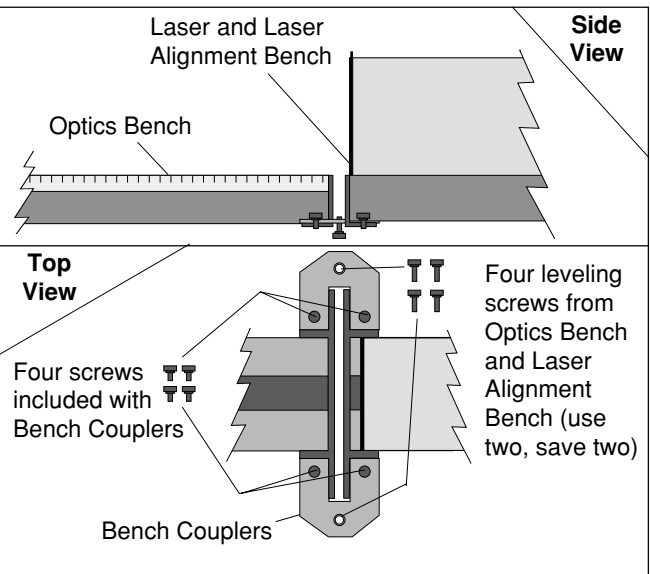
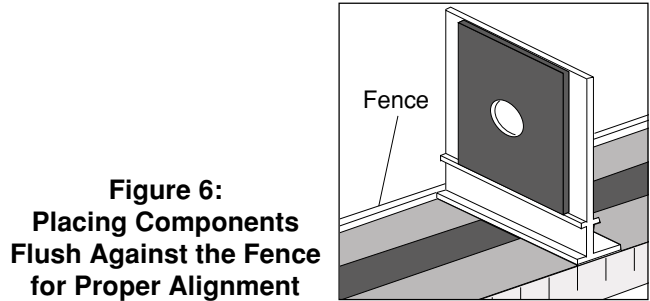

Figure 7: Coupling the Optics Bench and the Laser Alignment Bench

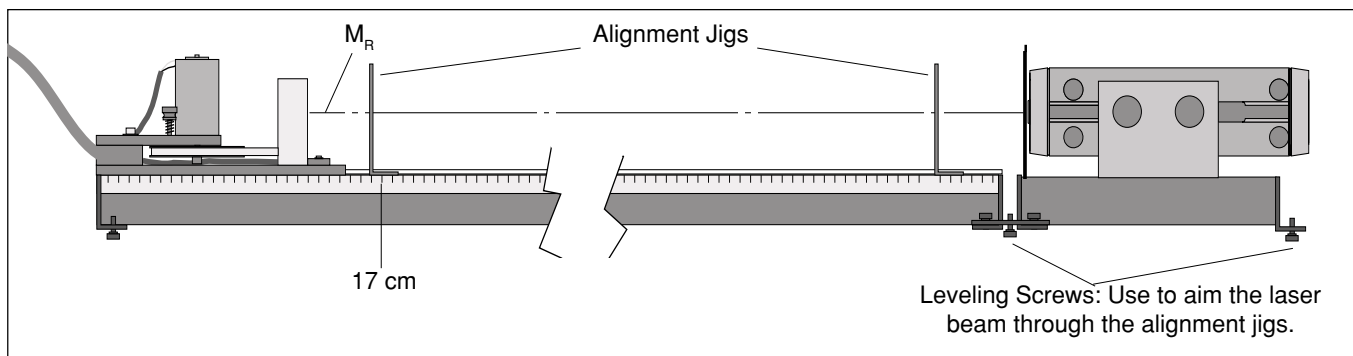

Figure 8: Using the Alignment Jigs to Align the Laser

To Set up and Align the Equipment:

1. Place the Optics Bench on a flat, level surface.
2. Place the Laser, mounted on the Laser Alignment Bench, end-to-end with the Optics Bench, at the end corresponding to the 1-meter mark of the metric scale.
3. Use the Bench Couplers and the provided screws to connect the Optics Bench and the Laser Alignment Bench. Details are shown in Figure 7. Do not yet tighten the screws holding the Bench Couplers.
 - Note that the leveling screws must be removed from the Optics Bench and from the Laser Alignment Bench to attach the Bench Couplers. Two of the removed leveling screws are then inserted into the threaded holes in the Bench Couplers and are used for leveling.
4. Mount the Rotating Mirror Assembly on the opposite end of the bench. Be sure the base of the assembly is flush against the fence of the Optics Bench and align the front edge of the base with the 17 cm mark on the metric scale of the Optics Bench (see Figure 8).

5. The laser must be aligned so the beam strikes the center of the Rotating Mirror (M_R). Two alignment jigs are provided for this purpose. Place one jig at each end of the Optics Bench as shown in Figure 8, with the edges flush against the fence of the bench. When properly placed, the holes in the jigs define a straight line that is parallel to the axis of the Optics Bench.
6. Turn on the Laser.

➤ **CAUTION:** Do not look into the laser beam, either directly or as it reflects from either mirror. Also, when arranging the equipment, be sure the beam path does not traverse an area where someone might inadvertently look into the beam.

7. Adjust the position of the front of the laser so the beam passes directly through the hole in the first jig. (Use the two front leveling screws to adjust the height. Adjust the position of the laser on the Laser Alignment Bench to adjust the lateral position.) Then adjust the height and position of the rear of the laser so the beam passes directly through the hole in the second jig.

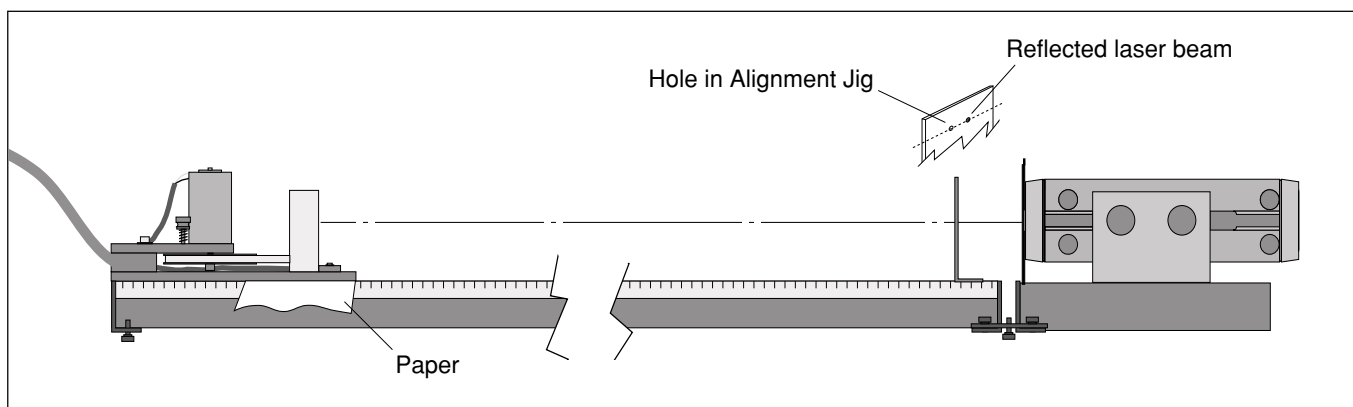

Figure 9: Aligning the Rotating Mirror (M_R)

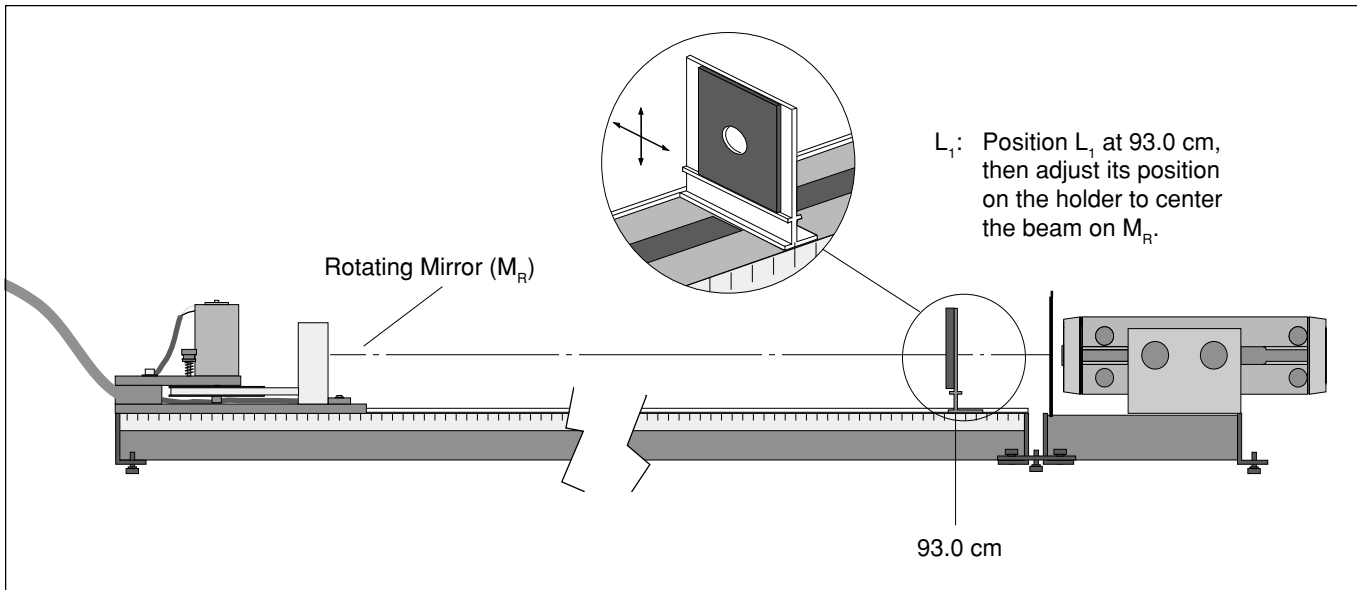

Figure 10: Positioning and Aligning L_1

8. To fix the laser in position with respect to the Optics Bench, tighten the screws on the Bench Couplers. Then recheck the alignment of the laser.
9. Align the Rotating Mirror. M_R must be aligned so that its axis of rotation is vertical and also perpendicular to the laser beam. To accomplish this, remove the second alignment jig and then rotate M_R so that the laser beam reflects back toward the hole in the first alignment jig (Figure 9). Be sure to use the reflective side of the mirror. It helps to tighten the lock-screw on the rotating mirror assembly just enough so M_R holds its position as you adjust its rotation.
If needed, use pieces of paper to shim between the Rotating Mirror Assembly and the Optics Bench so that the laser beam is reflected back through the hole in the first jig.
10. Remove the first alignment jig.
11. Mount the 48 mm focal length lens (L_1) on the Optics Bench so that the center line of the Component Holder is aligned with the 93.0 cm mark on the metric scale of the bench. Without moving the Component Holder, slide L_1 as needed on the holder to center the beam on M_R (see Figure 10). Notice that L_1 has spread the beam at the position of M_R .
12. Mount the 252 mm focal length lens (L_2) on the Optics Bench so the center line of the Component Holder aligns with the 62.2 cm mark on the metric scale of the bench. As for L_1 in step 11, adjust the position of L_2 on the Component Holder so that the beam is again centered on M_R .
13. Place the Measuring Microscope on the Optics Bench so that the left edge of the mounting stage is aligned with the 82.0 cm mark on the bench (see Figure 5). The lever that adjusts the tilt of the beam splitter should be on the same side as the metric scale of the Optics Bench. Position this lever so it points directly down.

➤ CAUTION: Do not look through the microscope until the polarizers have been placed between the laser and the beam splitter in step 19.

The beamsplitter will slightly alter the position of the laser beam. Readjust L_2 on the Component Holder so the beam is again centered on M_R .

14. Place the Fixed Mirror (M_F) from 2 to 15 meters from M_R , as shown in Figure 11. The angle between the axis of the Optics Bench and a line from M_R to M_F should be approximately 12 degrees. (If it is greater than 20-degrees, the reflected beam will be blocked by the Rotating Mirror enclosure.) Also be sure that M_F is not on the same side of the optical bench as the micrometer knob, so you will be able to make the measurements without blocking the beam.

➤ NOTE: Best results are obtained when M_F is 10 to 15 meters from M_R . See *Notes on Accuracy* near the end of the manual.

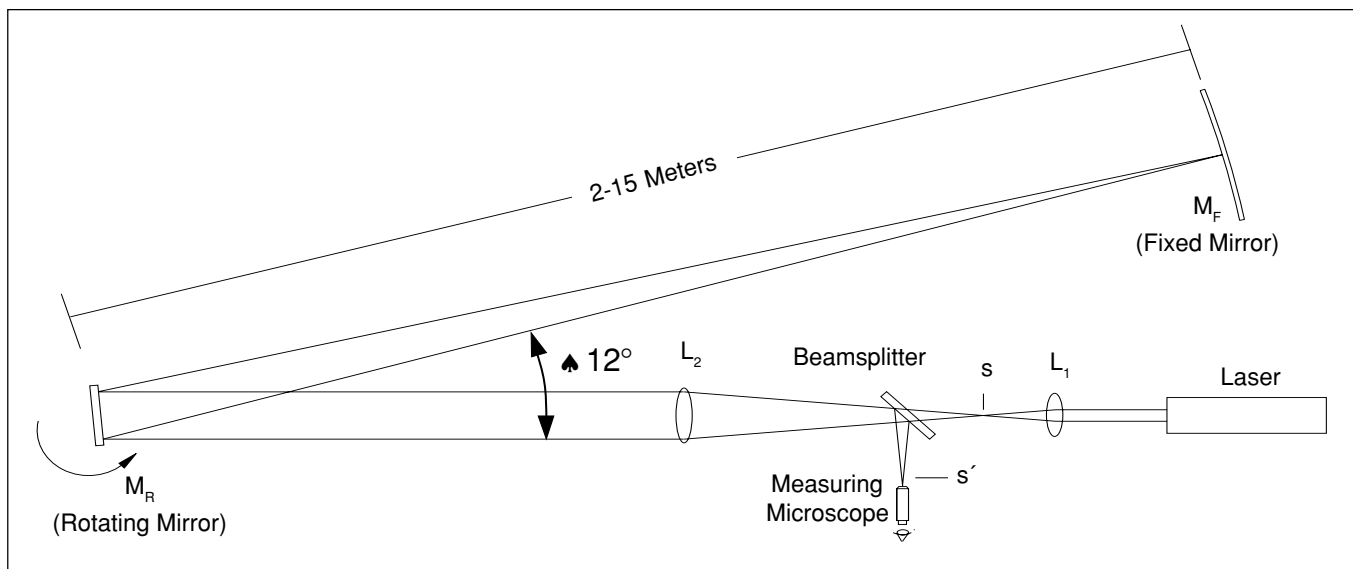

Figure 11: Positioning the Fixed Mirror (M_F)

15. Position M_R so the laser beam is reflected toward M_F . Place a piece of paper in the beam path and “walk” the beam toward M_F , adjusting the rotation of M_R as needed.
 16. Adjust the position of M_F so the beam strikes it approximately in the center. Again, a piece of paper in the beam path will make the beam easier to see.
 17. With a piece of paper still against the surface of M_F , slide L_2 back and forth along the Optics Bench to focus the beam to the smallest possible point on M_F .
 18. Adjust the two alignment screws on the back of M_F so the beam is reflected directly back to the center of M_R . This step is best performed with two people: one adjusting M_F , and one watching the beam position at M_R .
 19. Place the polarizers (attached to either side of a single Component Holder) between the laser and L_1 . Begin with the polarizers at right angles to each other, then rotate one until the image in the microscope is bright enough to view comfortably.
- Loosen the lock-screw on the microscope. As shown in Figure 13, remove the microscope and place a piece of tissue paper over the tube to locate the beam. Adjust the beamsplitter angle and the micrometer knob to center the point image in the tube of the microscope.
 - Slide the Measuring Microscope a centimeter or so in either direction along the axis of the Optics Bench. Be sure that the Microscope stays flush against the fence of the Optics Bench. If this doesn't work, re-check the alignment, beginning with step 1.
20. Bring the cross-hairs of the microscope into focus by sliding the microscope eyepiece up and down.
 21. Focus the microscope by loosening the lock-screw and sliding the scope up and down. If the apparatus is properly aligned, you will see the point image through the microscope. Focus until the image is as sharp as possible.

If you can't find the point image there are several things you can try:

- Vary the tilt of the beamsplitter slightly (no more than a few degrees) and turn the micrometer knob to vary the transverse position of the microscope until the image comes into view.

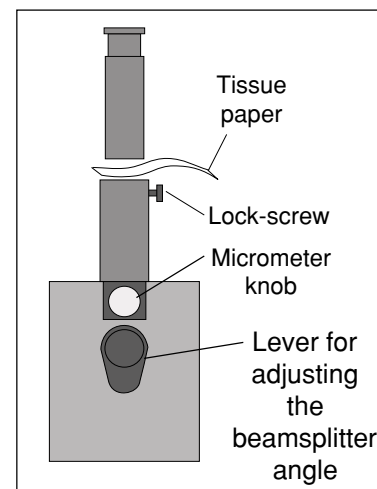

Figure 13: Looking for the Beam Image

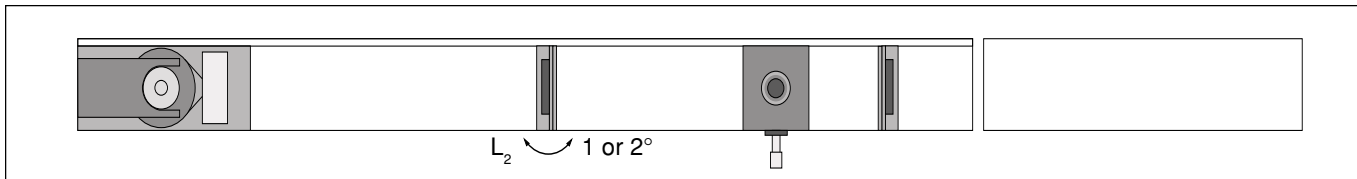

Figure 12: Turning L_2 Slightly Askew to Clean Up the Image

► **IMPORTANT:** In addition to the point image, you may also see some extraneous beam images resulting, for example, from reflection of the laser beam from L_1 . To be sure you are observing the right image point, place a piece of paper between M_R and M_F while you watch the image in the microscope. If the point does not disappear, it is not the correct image.

Cleaning Up the Image

22. In addition to the point image, you may also see interference fringes through the microscope (as well as the extraneous beam images mentioned above). These fringes cause no difficulty as long as the point image is clearly visible. However, the fringes and extraneous beam images can sometimes be removed without losing the point image. This is accomplished by turning L_2 slightly askew, so it is no longer quite at a right angle to the beam axis (see Figure 12).

Alignment Summary

(see Figure 14 for approximate component placement)

This summary is for those who are familiar with the equipment and the experiment, and just need a quick reminder of the steps in the alignment procedure. If you have not successfully aligned the apparatus before, we recommend that you take the time to go through the detailed alignment procedure in the preceding section.

1. Align the laser so the laser beam strikes the center of M_R (use the alignment jigs).
2. Adjust the rotational axis of M_R so it is perpendicular to the beam (i.e. as M_R rotates, there must be a position at which it reflects the laser beam directly back into the laser aperture).
3. Insert L_1 to focus the laser beam to a point. Adjust L_1 so the beam is still centered on M_R .
4. Insert L_2 and adjust it so the beam is still centered on M_R .
5. Place the Measuring Microscope in position and, again, be sure that the beam is still centered on M_R .

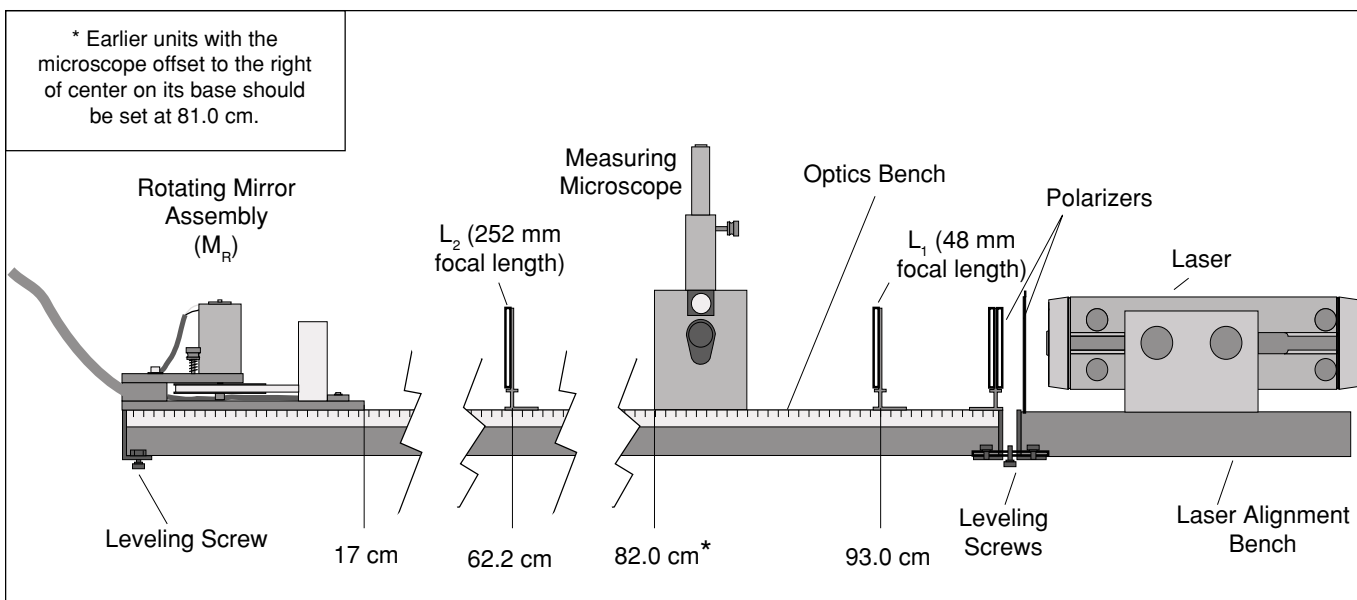

Figure 14: Equipment Alignment

► **CAUTION:** Do not look through the microscope until the polarizers have been placed between the laser and the beamsplitter.

6. Position M_F at the chosen distance from M_R (2 - 15 meters), so the reflected image from M_R strikes the center of M_F .
7. Adjust the position of L_2 to focus the beam to a point on M_F .
8. Adjust M_F so the beam is reflected directly back onto M_R .
9. Insert the polarizers between the laser and the beam splitter.
10. Focus the microscope on the image point.
11. Remove polarizers.

Alignment Hints

Once you have the microscope focused, it may still be difficult to obtain a good spot. There may be several other lights visible in the microscope besides the spot reflected from the fixed mirror.

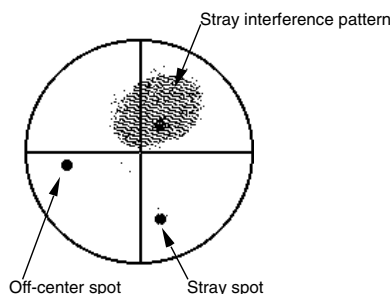

The most common of these are stray interference patterns. These are caused by multiple reflections from the surfaces of the lenses, and may be ignored. If necessary, you may be able to eliminate them by angling the lenses $1 - 2^\circ$.

Stray Spots are most often caused by reflections off the window of the rotating mirror housing. To determine which spot is the one you must measure, block the beam path between the rotating mirror and the fixed mirror. The relevant spot will disappear.

If the spot you need to measure is significantly off-center, you can move it by adjusting the angle of the beamsplitter.

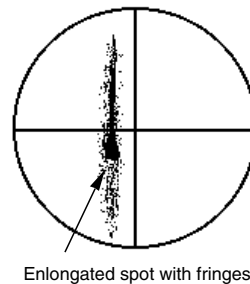

Another common problem is a spot that is “stretched” with no easily discernible maxima. Check first to make sure that this is the spot you need by blocking the beam path between the moving and fixed mirrors. If it is, then twist L_2 slightly until the image coalesces into a single spot.

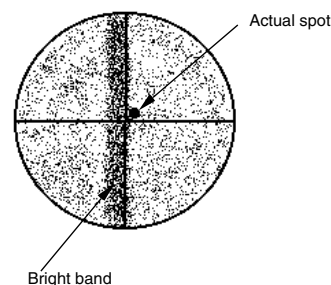

Once the mirror begins to rotate, it is safe to look into the microscope without the polarizers. You will notice that your carefully aligned pattern has changed: now the entire field is covered with a random interference pattern, and there is a bright band down the center of the field. Ignore the interference pattern; there's nothing you can do about it anyway. The band is the image of the laser when, once each rotation, the mirror reflects it into the microscope beamsplitter. This is also unavoidable.

Your actual spot will probably be just to one side of the bright band. You can check for it by blocking and unblocking the beam path between the rotating mirror and fixed mirror and watching to see what disappears.

If you aligned everything *perfectly*, the spot will be hidden by the bright band; in this case, make sure that you have a spot when the rotating mirror is fixed and is reflecting the laser to the fixed mirror. If you do have the correct spot under stationary conditions, then misalign the fixed mirror *very slightly* (0.004° or less) around the horizontal axis. This will bring the actual spot out from under the bright band.

Making the Measurement

The speed of light measurement is made by rotating the mirror at high speeds and using the microscope and micrometer to measure the corresponding deflection of the image point. By rotating the mirror first in one direction, then in the opposite direction, the total beam deflection is doubled, thereby doubling the accuracy of the measurement.

►► Important—to Protect the Rotating Mirror Assembly:

- Before turning on the motor, be sure the lock-screw for the rotating mirror is completely loosened, so the mirror rotates freely by hand.
- Whenever the speed of the motor is accelerated, the red LED on the front panel of the motor control box will light up. As the speed stabilizes, this light should go off. If it does not, turn off the motor. Something is interfering with the motor rotation. Check to be sure the lock-screw for M_R is fully loosened.
- Never run the motor with the MAX REV/SEC button pushed for more than one minute at a time, and always allow about a minute between runs for the motor to cool off.

1. With the apparatus aligned and the beam image in sharp focus (see the previous section), set the direction switch on the rotating mirror power supply to CW, and turn on the motor. If the image was not in sharp focus, adjust the microscope. You should also turn L_2 slightly askew (about $1 - 2^\circ$) to improve the image. To get the best image you may need to adjust the microscope and L_2 several times. Let the motor warm up at about 600 revolutions/sec for at least 3 minutes.
2. Slowly increase the speed of rotation. Notice how the beam deflection increases.
3. Use the ADJUST knob to bring the rotational speed up to about 1,000 revolutions/sec. Then push the MAX REV/SEC button and hold it down. When the rotation speed stabilizes, rotate the micrometer knob on the microscope to align the center of the beam image with the cross hair in the microscope that is perpendicular to the direction of deflection. Record the speed at which the motor is rotating, turn off the motor, and record the micrometer reading.

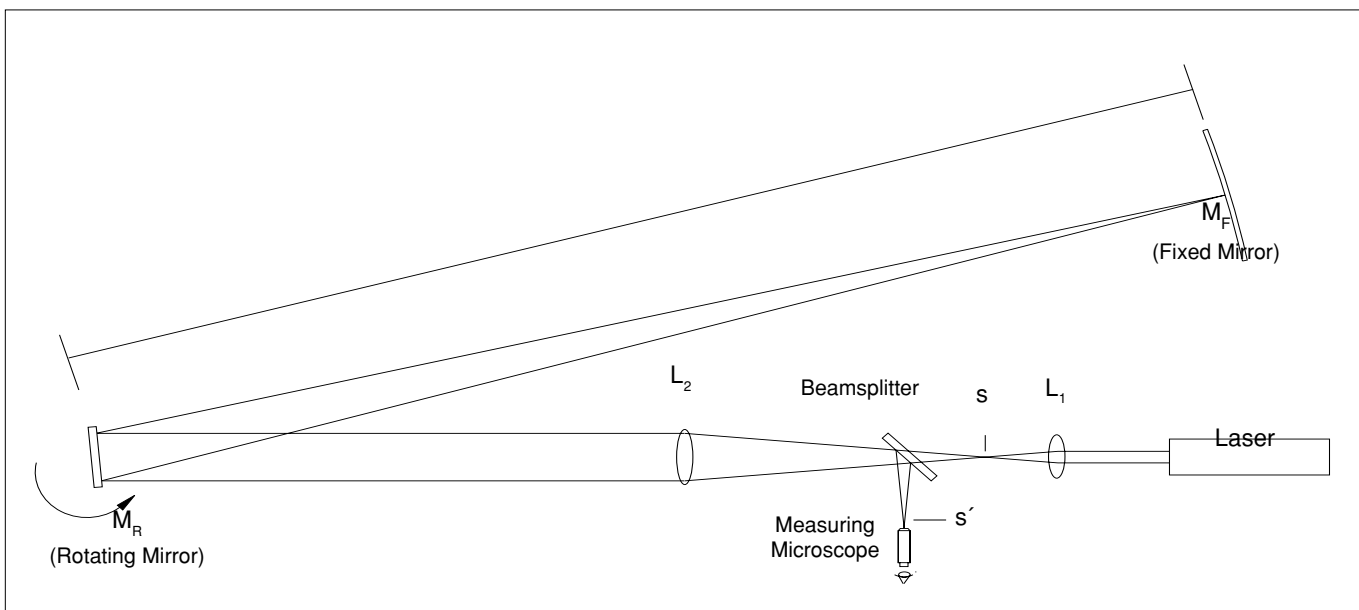

Figure 15: Diagram of the Foucault Method

➤ NOTE:

When reversing the direction of movement of the micrometer carriage, there will always be some movement of the micrometer knob before the carriage responds. Though this source of error is small, it can be eliminated. Just adjust the initial position of the micrometer stage so that you always turn the micrometer knob in the same direction as you adjust it.

Reverse the direction of the mirror rotation by switching the direction switch on the power supply to CCW. Allow the mirror to come to a complete stop before reversing the direction. Then repeat your measurement as in step 3.

➤ NOTES:

- When the mirror is rotated at 1,000 rev/sec or more, the image point will widen in the direction of displacement. Position the microscope cross-hair in the center of the resulting image.
- The micrometer on the Measuring Microscope is graduated in increments of 0.01 mm for the beam deflections.

5.) The following equation was derived earlier in the manual:

$$c = \frac{4AD^2\omega}{(D+B)\Delta s'}$$

When adjusted to fit the parameters just measured, it becomes:

$$c = \frac{8\pi AD^2(\text{Rev/sec}_{cw} + \text{Rev/sec}_{ccw})}{(D+B)(s'_{cw} - s'_{ccw})}$$

Use this equation, along with the diagram in Figure 15, to calculate c , the speed of light. (To measure A , measure the distance between L_1 and L_2 , then subtract the focal length of L_1 , 48 mm.)

➤ NOTES:

This equation is the same as the original equation in step 5, but with two differences:

The rotational velocity is expressed in rad/s.

The CCW rotational velocity is expressed as a negative number, reflecting the direction of rotation.

$$c = \frac{4AD^2(\omega_{cw} - \omega_{ccw})}{(D+B)(s'_{cw} - s'_{ccw})}$$

Notes on Accuracy and Maintenance

Accuracy

Precise alignment of the optical components and careful measurement are, of course, essential for an accurate measurement using this equipment. Beyond this, the main factor affecting accuracy is the distance between the fixed and rotating mirrors.

As mentioned in the alignment procedure, the optimum distance between M_R and M_F is from 10 to 15 meters. Within this range, accuracy within 5% is readily obtainable. If space is a problem, the distance between the mirrors can be reduced to as little as 1 meter and proportional reduction in accuracy will result.

In general, longer distances provide greater accuracy. M_R rotates farther as the light travels between the mirrors, and the image deflection is correspondingly greater. Greater deflections reduce the percentage of measurement error.

However, the optical components are designed for optimal focusing of the image point at 13.5 meters (this is the radius of curvature of M_F). Image focusing is not a significant problem as long as the distance between the mirrors is within about 15 meters. At larger distances the intensity and focus of the image point begins to drop, and measurement and alignment are hampered.

Typical sample data taken in our lab gives values for c that are within 1.5 - 2.5% of accepted values.

Maintenance

Regular maintenance for this equipment is minimal. The mirrors and lenses should be cleaned periodically.

► IMPORTANT: All mirrors and lenses may be cleaned with lens tissue, except the spherical mirror (M_F). It has a delicate aluminized front surface and should only be cleaned with alcohol and a soft cloth. Do not use any cleaning compound that contains ammonia (such as Windex); the ammonia will attack the aluminum surface.

If problems arise with the rotating mirror assembly, such as a broken drive belt, notify PASCO scientific. We do not recommend that you attempt to fix this equipment yourself. (See the warranty and equipment return information at the front of this manual.)

Technical Support

Feedback

If you have any comments about the product or manual, please let us know. If you have any suggestions on alternate experiments or find a problem in the manual, please tell us. PASCO appreciates any customer feedback. Your input helps us evaluate and improve our product.

To Reach PASCO

For technical support, call us at 1-800-772-8700 (toll-free within the U.S.) or (916) 786-3800.

fax: (916) 786-3292

e-mail: techsupp@pasco.com

web: www.pasco.com

Contacting Technical Support

Before you call the PASCO Technical Support staff, it would be helpful to prepare the following information:

- ▶ If your problem is with the PASCO apparatus, note:
 - Title and model number (usually listed on the label);
 - Approximate age of apparatus;
 - A detailed description of the problem/sequence of events (in case you can't call PASCO right away, you won't lose valuable data);
 - If possible, have the apparatus within reach when calling to facilitate description of individual parts.

- ▶ If your problem relates to the instruction manual, note:
 - Part number and revision (listed by month and year on the front cover);
 - Have the manual at hand to discuss your questions.



The lightning flash with arrowhead, within an equilateral triangle, is intended to alert the user of the presence of uninsulated “dangerous voltage” within the product’s enclosure that may be of sufficient magnitude to constitute a risk of electric shock to persons.



CAUTION:
TO PREVENT THE RISK OF ELECTRIC SHOCK, DO NOT REMOVE BACK COVER. NO USER SERVICEABLE PARTS INSIDE. REFER SERVICING TO QUALIFIED SERVICE PERSONNEL.



The exclamation point within an equilateral triangle is intended to alert the user of the presence of important operating and maintenance (servicing) instructions in the literature accompanying the appliance.

Table of Contents

Section	Page
Copyright, Warranty, and Equipment Return	ii
Introduction	1
Measuring the Velocity of Light: History	2
Galileo	
Römer	
Fizeau	
Foucault	
The Foucault Method	3
A Qualitative Description	
A Quantitative Description	
Equipment	6
Setup and Alignment	8
Alignment Summary	12
Alignment Hints	13
Making the Measurement	14
Notes on Accuracy and Maintenance	16

Copyright, Warranty, and Equipment Return

Please—Feel free to duplicate this manual subject to the copyright restrictions below.

Copyright Notice

The PASCO scientific 012-07135A Speed of Light Apparatus manual is copyrighted and all rights reserved. However, permission is granted to non-profit educational institutions for reproduction of any part of the manual providing the reproductions are used only for their laboratories and are not sold for profit. Reproduction under any other circumstances, without the written consent of PASCO scientific, is prohibited.

Limited Warranty

PASCO scientific warrants the product to be free from defects in materials and workmanship for a period of one year from the date of shipment to the customer. PASCO will repair or replace at its option any part of the product which is deemed to be defective in material or workmanship. The warranty does not cover damage to the product caused by abuse or improper use. Determination of whether a product failure is the result of a manufacturing defect or improper use by the customer shall be made solely by PASCO scientific. Responsibility for the return of equipment for warranty repair belongs to the customer. Equipment must be properly packed to prevent damage and shipped postage or freight prepaid. (Damage caused by improper packing of the equipment for return shipment will not be covered by the warranty.) Shipping costs for returning the equipment after repair will be paid by PASCO scientific.

Credits

This manual authored by: Bruce Lee

This manual edited by: Dave Griffith

Equipment Return

Should the product have to be returned to PASCO scientific for any reason, notify PASCO scientific by letter, phone, or fax BEFORE returning the product. Upon notification, the return authorization and shipping instructions will be promptly issued.

► **NOTE: NO EQUIPMENT WILL BE ACCEPTED FOR RETURN WITHOUT AN AUTHORIZATION FROM PASCO.**

When returning equipment for repair, the units must be packed properly. Carriers will not accept responsibility for damage caused by improper packing. To be certain the unit will not be damaged in shipment, observe the following rules:

- ① The packing carton must be strong enough for the item shipped.
- ② Make certain there are at least two inches of packing material between any point on the apparatus and the inside walls of the carton.
- ③ Make certain that the packing material cannot shift in the box or become compressed, allowing the instrument come in contact with the packing carton.

Address: PASCO scientific
10101 Foothills Blvd.
Roseville, CA 95747-7100

Phone: (916) 786-3800
FAX: (916) 786-3292
email: techsupp@pasco.com
web: www.pasco.com