

Smart Temperatursensor

Bestellnummer 116.4021



Im Lieferumfang enthalten
- Smart Temperatursensor

Zusätzlich erforderlich: Software SPARKvue oder Capstone von PASCO

Schnellstart für Smartphones

Kostenlose App für Android und iOS



Zur iOS-App

Scannen Sie den QR-Code ein und Sie gelangen direkt zur kostenlosen App „SPARKvue“ in Ihrem AppStore. Sie installieren die App auf Ihrem Endgerät (Tablet / Smartphone mit iOS oder Android).



Zur Android-App

Für Windows PC und Mac finden Sie eine kostenpflichtige Variante unter >><https://www.conatex.com/catalog/sku-1104020>.

Einschalten

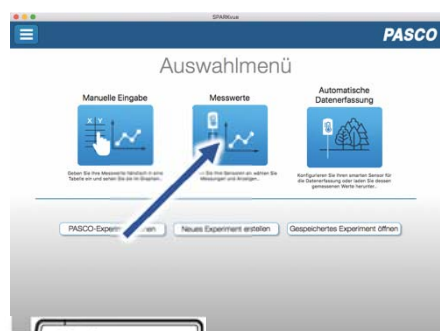

Draufsicht

Sie schalten Ihren Sensor auf der Oberseite ein und starten die SPARKvue App. Auf dem Startbildschirm wählen Sie in der Mitte den Punkt „Messwerte“.

Verbinden

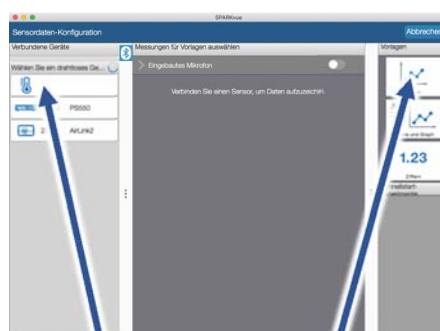

Sensorauswahl

Darstellung

Sie kommen zur Sensor-Konfiguration. In der linken Spalte wählen Sie Ihren Sensor aus. Danach können Sie rechts die Darstellung der Messwerte aussuchen.

Messen & Auswerten



Messung starten & beenden

Um eine Messung zu starten klicken Sie auf den grünen Knopf mittig unten in der Leiste. Die Messung beendet Sie in dem Sie wieder auf das nun rote Quadrat drücken.



Mit folgendem QR-Code gelangen Sie direkt zu unserer kostenlosen Video-Anleitung. Diese finden Sie in unserem Webshop auch bei der Lizenz von SPARKvue unter >><http://www.conatex.com/q1104020>. Dort finden Sie auch Betriebsanleitungen zum kostenlosen Download.



Zweck und bestimmungsgemäßer Gebrauch

Der Smart-Temperatursensor verfügt über eine Sonde aus rostfreiem Edelstahl. Er lässt sich drahtlos über Bluetooth an Smartphones, Tablets und Computer anschließen.

Mit einem eigenen Speicher ausgestattet, ist er außerdem in der Lage Messwerte selbstständig zu erfassen und anschließend als Block zu übertragen.

Der Sensor misst Temperaturen im Bereich von -40°C bis $+125^{\circ}\text{C}$.

ACHTUNG !

Temperaturen über 140°C , wie sie mit einem Feuerzeug leicht zu erreichen sind, zerstören den Sensor.

Betrieben wird der Sensor von einer 3 Volt Knopfzelle, deren Lebensdauer im Normalfall ein Jahr übersteigt.

Handhabung

Da jeder Sensor eine eindeutige Geräte-ID hat können gleichzeitig mehrere Sensoren an dasselbe Gerät angeschlossen werden. Das Sensorgehäuse ist wasserdicht. Eintauchen kann schnell zum Verlust der Funkverbindung führen. Bringen Sie nur die Metallsonde in den zu untersuchenden Stoff ein. **ACHTUNG!** Das Sensorgehäuse nicht in kochend heißes Wasser eintauchen.

Verbinden

Klicken Sie auf das Feld „Messwerte“. Es erscheint eine Übersicht zur „Sensordaten-konfiguration“. Hier sehen Sie links die Sensoren, die schon verbunden sind, und die, die Sie noch verbinden können. Der oberste Sensor in der zweiten Liste liegt normalerweise am nächsten zu Ihrem Endgerät. Zum Abgleichen hat jeder Sensor eine Geräte-ID, damit Sie diese mit der angezeigten ID vergleichen können.

Messen

Um eine Messung zu starten müssen Sie jetzt nur noch in der rechten Spalte eine Vorlage auswählen oder direkt in ein Schnellstart-Experiment springen. Wenn Sie danach unten auf den grünen Start-Knopf klicken erfassen Sie schon Messwerte.

Data-Logger

Alle weißen PASCO Sensoren haben eine eingebaute Datalogger-Funktion. Diese aktivieren Sie, indem Sie im Startbildschirm auf „Automatische Messwerterfassung“ klicken. Es öffnet sich ein Dialog, indem Sie einen Sensor zum Loggen vorbereiten können, oder die automatisch erfassten Daten herunterladen können. Sie wählen Ihren Sensor aus und stellen die gewünschte Abtastrate ein. Abhängig davon zeigt dieser Dialog Ihnen für wie viele Stunden der Speicher des Sensors ausreicht.



Eine Video-Anleitung dazu finden Sie unter <https://www.youtube.com/watch?v=1lin5ToaxK0>.

Die Daten können Sie auf dem gleichen Weg von Sensor herunterladen, indem Sie statt diesen vorzubereiten einfach im Bereich „Sensor mit Messwerten“ auswählen und die Daten herunterladen und sich anzeigen lassen.

LED-Informationen

Die Leuchtanzeigen für Bluetooth und den Batteriestatus haben folgende Bedeutungen:

Bluetooth-LED	Status
Rot blinkend	Bereit
Grün blinkend	Verbunden
Gelb blinkend	Erfassung läuft Oder Automatik bereit
Gelb-Rot funkelnd	Automat. Erfassung läuft
AUS	Datenerfassung über USB

Akkuanzeige	Status
Rot blinkend	Schwache Akkuladung
Gelb dauernd	Aufladen
Grün dauernd	Vollständig geladen

Entweder überträgt der Sensor laufend Messwerte an ein gekoppeltes Gerät oder er speichert sie intern. Gespeicherte Messreihen können bei der nächsten Verbindung mit PASCOSoftware ausgelesen werden. Die unabhängige Messwernerfassung empfiehlt sich besonders für Langzeitexperimente.

Technische Spezifikationen

Messbereich	-40°C bis +125°C
Genauigkeit	±0,5° C
Auflösung	0,01° C
Maximale Abtastrate	10 Hz
Temperaturverträglichkeit Gehäuse*	-15°C bis +50°C

* Bei längerer Übertretung dieses Temperaturbereichs wird die Batterie in Mitleidenschaft gezogen.

Fehlerbehebung

Versuchen Sie eine abgerissene Bluetooth-Verbindung wiederherzustellen, indem Sie die EIN/AUS-Taste des Adapters gedrückt halten, bis die Status-LEDs nacheinander blinken.

Lagerung und Pflege

Spülen und trocknen Sie die Sonde nach jeder Benutzung. Lagern Sie den Sensor an einem kühlen, trockenen Ort. Wenn Sie vorhaben, den Sensor für Monate unbenutzt zu lagern, entfernen Sie unbedingt die Batterie.

Sicherheitshinweise

- Vor Inbetriebnahme des Gerätes ist die Bedienungsanleitung sorgfältig und vollständig zu lesen. Sie schützen sich und vermeiden Schäden an Ihrem Gerät.
- Verwenden Sie das Gerät nur für den vorgesehenen Zweck.
- Das Gerät nicht öffnen.

Entsorgungshinweise

Elektro-Altgeräte Entsorgung



Es obliegt Ihrer Verantwortung, Ihr elektronisches Gerät gemäß den örtlichen Umweltgesetzen und -vorschriften zu recyceln, um sicherzustellen, dass es auf eine Weise recycelt wird, die die menschliche Gesundheit und die Umwelt schützt. Um zu erfahren, wo Sie Ihre Altgeräte zum Recycling abgeben können, wenden Sie sich bitte an Ihren örtlichen Abfallentsorgungsdienst oder an den Ort, an dem Sie das Produkt gekauft haben. Das WEEE-Symbol der Europäischen Union und auf dem Produkt oder seiner Verpackung weist darauf hin, dass dieses Produkt NICHT mit dem normalen Hausmüll entsorgt werden darf.

Batterie Entsorgung



Batterien enthalten Chemikalien, die, wenn sie freigesetzt werden, die Umwelt und die menschliche Gesundheit beeinträchtigen können. Batterien sollten für das Recycling getrennt gesammelt und an einer örtlichen Entsorgungsstelle für gefährliche Stoffe unter Einhaltung der Vorschriften Ihres Landes und der örtlichen Behörden wiederverwertet werden. Um herauszufinden, wo Sie Ihre Altbatterie zum Recycling abgeben können, wenden Sie sich bitte an Ihren örtlichen Abfallentsorgungsdienst oder an den Produktvertreter. Die in diesem Produkt verwendete Batterie ist mit den internationalen Symbolen gekennzeichnet, um die Notwendigkeit der getrennten Sammlung und des Recyclings von Batterien anzuzeigen.

Technische Unterstützung

Für weitere technische Unterstützung wenden Sie sich an:

CONATEX DIDACTIC Lehrmittel GmbH
Zinzinger Straße 11
66117 Saarbrücken - Deutschland

Hotline Digital-Team: +49 (0)6849 – 99 296-54
Kundenservice (kostenfrei): 00800 0266 2839 oder +49 (0) 6849 – 99 296-0

Internet: <https://www.conatex.com>
Email: digital-team@conatex.com

Smart Blutdrucksensor

Bestellnummer 118.4032

Im Lieferumfang enthalten

- Smart Blutdrucksensor
- Blutdruckmanschette in mittlerer Größe
- Micro USB Kabel (1 Meter)

Zusätzlich erforderlich: Software SPARKvue oder Capstone von PASCO



Schnellstart für Smartphones

Kostenlose App für Android und iOS



Zur iOS-App

Scannen Sie den QR-Code ein und Sie gelangen direkt zur kostenlosen App „SPARKvue“ in Ihrem AppStore. Sie installieren die App auf Ihrem Endgerät (Tablet / Smartphone mit iOS oder Android).



Zur Android-App

Für Windows PC und Mac finden Sie eine kostenpflichtige Variante unter >><https://www.conatex.com/catalog/sku-1104020>.

Einschalten



Draufsicht

Verbinden

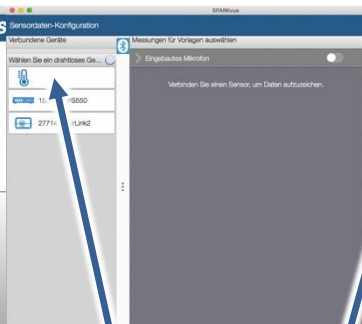

Sensorauswahl

Messen & Auswerten

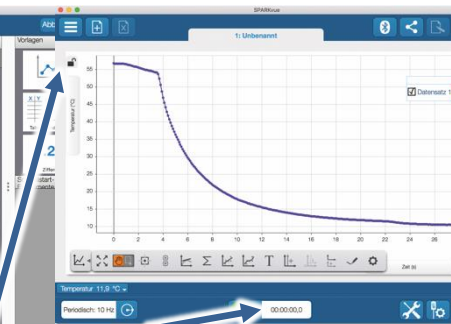

Darstellung

Messung starten & beenden

Sie schalten Ihren Sensor auf der Oberseite ein und starten die SPARKvue App. Auf dem Startbildschirm wählen Sie in der Mitte den Punkt „Messwerte“.

Sie kommen zur Sensor-Konfiguration. In der linken Spalte wählen Sie Ihren Sensor aus. Danach können Sie rechts die Darstellung der Messwerte aussuchen.

Um eine Messung zu starten klicken Sie auf den grünen Knopf mittig unten in der Leiste. Die Messung beendet Sie indem Sie wieder auf das nun rote Quadrat drücken.



Mit folgendem QR-Code gelangen Sie direkt zu unserer kostenlosen Video-Anleitung. Diese finden Sie in unserem Webshop auch bei der Lizenz von SPARKvue unter >><http://www.conatex.com/q1104020>. Dort finden Sie auch Betriebsanleitungen zum kostenlosen Download.

Zweck und bestimmungsgemäßer Gebrauch

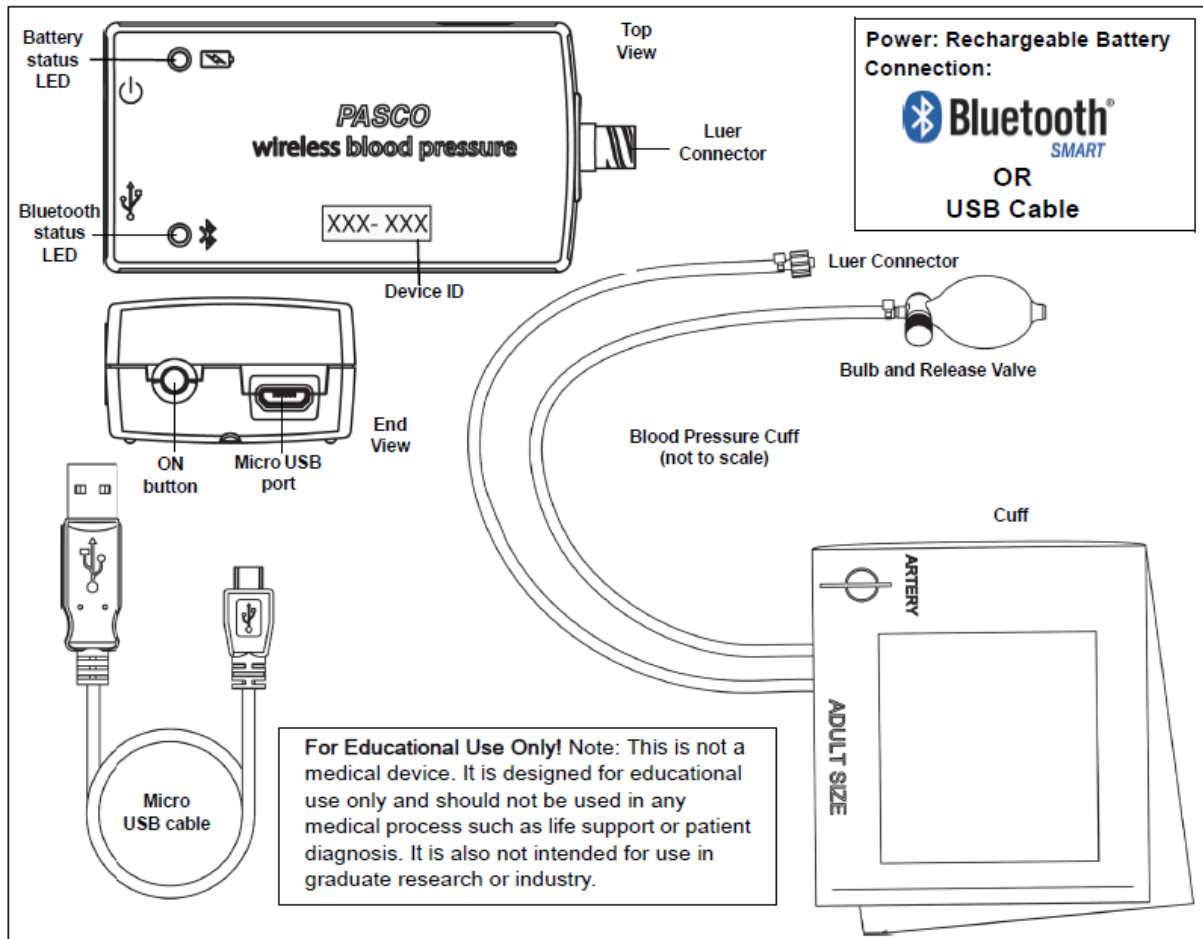

Der Sensor misst Gasdruck im Bereich von 0 mmHg bis 260 mmHg und zusätzlich die Herzfrequenz.

Er verwendet die oszillometrische Technik zur Schätzung des Blutdrucks. Wenn die Druckschwankungen in einer Blutdruckmanschette während der allmählichen Entleerung aufgezeichnet werden, entspricht der Punkt der maximalen Schwingung dem mittleren intraarteriellen Druck. Die Oszillationen beginnen ungefähr bei systolischem Druck und setzen sich unterhalb des diastolischen Drucks fort, so dass systolischer und diastolischer Druck nur indirekt nach einem empirisch abgeleiteten Algorithmus geschätzt werden können.

Handhabung

Der Sensor selbst verfügt über einen Luer-Lock Anschluss und lässt sich problemlos an der Manschette anschließen.

ACHTUNG!

Pumpen Sie die Manschette nicht über 200 mmHg auf. Sie können zu hohen Druck rasch ablassen, indem Sie das Ventil an der Pumpe betätigen.

Der Proband sollte entspannt sitzen, ohne die Beine zu überkreuzen, den linken Ellenbogen und Unterarm mit der Handfläche nach oben auf eine feste Unterlage. Die Manschette sollte am Ende etwas niedriger das Herz sein.

Ein Helfer sollte über das Ventil die Manschette zunächst komplett entleeren und dann so anlegen, dass die Unterkante etwa 2,5 cm oberhalb der Ellenbogengrube liegt und die Pfeilmarkierung an der Innenseite des Armes auf die Hauptarterie zeigt.

Nachdem Sie den Sensor mit der Messwerterfassungssoftware verbunden haben, steht ein vorkonfiguriertes Experiment zur Blutdruckmessung zur Verfügung, das den Manschettendruck aufzeichnet und daraus systolischen und diastolischen Druck ableitet, sobald das möglich ist.

Der Helfer startet das Experiment und pumpt dann mit Hilfe der angezeigten Messwerte die Manschette auf etwa 160 mmHg auf. Anschließend verliert die Manschette automatisch etwa 3mmHg pro Sekunde, womit die Messung nach ungefähr einer Minute abgeschlossen ist.

Verbinden

Klicken Sie auf das Feld „Messwerte“. Es erscheint eine Übersicht zur „Sensordatenkonfiguration“. Hier sehen Sie links die Sensoren, die schon verbunden sind, und die, die Sie noch verbinden können. Der oberste Sensor in der zweiten Liste liegt normalerweise am nächsten zu Ihrem Endgerät. Zum Abgleichen hat jeder Sensor eine Geräte-ID, damit Sie diese mit der angezeigten ID vergleichen können.

Messen

Um eine Messung zu starten müssen Sie jetzt nur noch in der rechten Spalte eine Vorlage auswählen oder direkt in ein Schnellstart-Experiment springen. Wenn Sie danach unten auf den grünen Start-Knopf klicken erfassen Sie schon Messwerte.

Data-Logger

Alle weißen PASCO Sensoren haben eine eingebaute Datalogger-Funktion. Diese aktivieren Sie, indem Sie im Startbildschirm auf „Automatische Messwerterfassung“ klicken. Es öffnet sich ein Dialog, indem Sie einen Sensor zum Loggen vorbereiten können, oder die automatisch erfassten Daten herunterladen können. Sie wählen Ihren Sensor aus und stellen die gewünschte Abtastrate ein. Abhängig davon zeigt dieser Dialog Ihnen für wie viele Stunden der Speicher des Sensors ausreicht.

Eine Video-Anleitung dazu finden Sie unter
>><https://www.youtube.com/watch?v=1lin5ToaxK0>.

Die Daten können Sie auf dem gleichen Weg von Sensor herunterladen, indem Sie statt diesen vorzubereiten einfach im Bereich „Sensor mit Messwerten“ auswählen und die Daten herunterladen und sich anzeigen lassen.

Technische Spezifikationen

Messbereich	0 – 260 mmHg
Genauigkeit	±3 mmHg
Auflösung	0,05 mmHg
Max. Abtastrate	100 Hz



LED-Informationen

Die Leuchtanzeigen für Bluetooth und den Batteriestatus haben folgende Bedeutungen:

Bluetooth-LED	Status
Rot blinkend	Bereit
Grün blinkend	Verbunden
Gelb blinkend	Erfassung läuft Oder Automatik bereit
Gelb-Rot funkeIn	Automat. Erfassung läuft
AUS	Datenerfassung über USB

Akkuanzeige	Status
Rot blinkend	Schwache Akkuladung
Gelb dauernd	Aufladen
Grün dauernd	Vollständig geladen

Entweder überträgt der Sensor laufend Messwerte an ein gekoppeltes Gerät oder er speichert sie intern. Gespeicherte Messreihen können bei der nächsten Verbindung mit PASCO Software ausgelesen werden. Die unabhängige Messwerterfassung empfiehlt sich besonders für Langzeitexperimente.

Fehlerbehebung

Versuchen Sie eine abgerissene Bluetooth-Verbindung wiederherzustellen, indem Sie die EIN/AUS-Taste des Adapters gedrückt halten, bis die Status-LEDs nacheinander blinken.

Lagerung und Pflege

Spülen und trocknen Sie die Sonde nach jeder Benutzung. Lagern Sie den Sensor an einem kühlen, trockenen Ort. Wenn Sie vorhaben, den Sensor für Monate unbenutzt zu lagern, entfernen Sie unbedingt die Batterie.

Sicherheitshinweise

- Vor Inbetriebnahme des Gerätes ist die Bedienungsanleitung sorgfältig und vollständig zu lesen. Sie schützen sich und vermeiden Schäden an Ihrem Gerät.
- Verwenden Sie das Gerät nur für den vorgesehenen Zweck.
- Das Gerät nicht öffnen.

Entsorgungshinweise

Elektro-Altgeräte Entsorgung



Es obliegt Ihrer Verantwortung, Ihr elektronisches Gerät gemäß den örtlichen Umweltgesetzen und -vorschriften zu recyceln, um sicherzustellen, dass es auf eine Weise recycelt wird, die die menschliche Gesundheit und die Umwelt schützt. Um zu erfahren, wo Sie Ihre Altgeräte zum Recycling abgeben können, wenden Sie sich bitte an Ihren örtlichen Abfallentsorgungsdienst oder an den Ort, an dem Sie das Produkt gekauft haben. Das WEEE-Symbol der Europäischen Union und auf dem Produkt oder seiner Verpackung weist darauf hin, dass dieses Produkt NICHT mit dem normalen Hausmüll entsorgt werden darf.

Batterie Entsorgung



Batterien enthalten Chemikalien, die, wenn sie freigesetzt werden, die Umwelt und die menschliche Gesundheit beeinträchtigen können. Batterien sollten für das Recycling getrennt gesammelt und an einer örtlichen Entsorgungsstelle für gefährliche Stoffe unter Einhaltung der Vorschriften Ihres Landes und der örtlichen Behörden wiederverwertet werden. Um herauszufinden, wo Sie Ihre Altbatterie zum Recycling abgeben können, wenden Sie sich bitte an Ihren örtlichen Abfallentsorgungsdienst oder an den Produktvertreter. Die in diesem Produkt verwendete Batterie ist mit den internationalen Symbolen gekennzeichnet, um die Notwendigkeit der getrennten Sammlung und des Recyclings von Batterien anzuzeigen.

Technische Unterstützung

Für weitere technische Unterstützung wenden Sie sich an:

CONATEX DIDACTIC Lehrmittel GmbH

Zinzinger Straße 11

66117 Saarbrücken - Deutschland

Hotline Digital-Team: +49 (0)6849 – 99 296-54

Kundenservice (kostenfrei): 00800 0266 2839 oder +49 (0) 6849 – 99 296-0

Internet: <https://www.conatex.com>

Email: digital-team@conatex.com

About the product



The Wireless EKG Sensor measures electrical signals produced by the heart. The EKG trace, displayed on a connected device, graphically illustrates the beating of the heart.

Note: This is not a medical device. It is designed for educational use only and should not be used in any medical process such as life support or patient diagnosis. It is not intended for use in graduate research or industry including industrial control or any type of industrial testing.

What's Included

- Wireless EKG Sensor
- 100× Electrode Patches (not pictured)
- USB Cable

Required Items

- **Data Collection Software**
This product requires either SPARKvue or PASCO Capstone for data collection and analysis.

Part names and descriptions

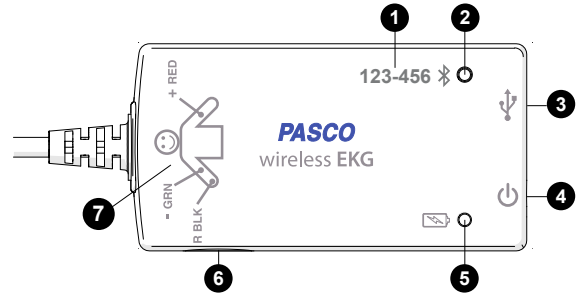

1 Device ID
Use to identify the sensor when connecting using Bluetooth.

2 Bluetooth Status Light
Indicates the status of the Bluetooth connection.

LIGHT	STATUS
Red, blink	Ready to pair
Green, blink	Paired
Yellow, blink	Remotely logging data

3 USB Port
Use with the USB cable to connect to a USB wall charger to charge the battery. Also use to send measurement data to software when connected to a USB port of a computer or mobile device (iOS devices not supported).

4 Power Button
Press and hold for one second to turn the sensor on or off.

5 Battery Status Light
Indicates the battery level and charging status.

LIGHT	STATUS
Red, blink	Low battery level
Green, solid	Fully charged
Yellow, solid	Charging

6 Threaded Hole
Use for mounting the sensor, such as to a mounting rod. Accepts 1/4-in-20 screws.

7 Connection Diagram
This diagram provides a reminder on how to correctly attach the EKG leads to a person. Connect the red (+) lead to the left forearm, the green (-) lead to the right forearm, and the black (R) lead to the right wrist. See the **Connect the sensor to a person** section for detailed instructions.

8 EKG Leads (not pictured)
Three alligator-clip leads are attached to the sensor box by a wire. The leads attach to the electrode patches that are applied to the skin.

Getting started

Perform the tasks in this section before using this device in the classroom.

Charge the battery

The Wireless EKG Sensor contains a rechargeable battery that lasts an entire school day when fully charged. Charge the battery before using the Wireless EKG Sensor for the first time since it is not shipped with a full charge.

To charge the battery, connect the sensor to a USB wall charger or powered USB port using the USB cable. The battery status light is solid yellow while the battery is charging and changes to solid green when fully charged.

Install or update data collection software

The latest update of PASCO Capstone or SPARKvue is required to use the Wireless EKG Sensor. Download and install the software from the PASCO website. Check if an update is available if the software is already installed.

SPARKvue

Windows and Mac Computers

Download: Go to [pasco.com/sparkvue](https://www.pasco.com/sparkvue) then click **Downloads**.

Update: Click  then select **Check for Updates**.

Mobile Devices and Chromebooks

Search for SPARKvue in your device's app store. SPARKvue automatically installs updates.

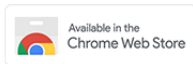

PASCO Capstone

Windows and Mac Computers

Download: Go to [pasco.com/capstone](https://www.pasco.com/capstone) then click **Downloads**.

Update: Click **Help** then select **Check for updates**.

Check for a firmware update

Update the sensor firmware to access the latest features and bug fixes. Sensor firmware is installed using SPARKvue or PASCO Capstone. Connect the sensor to SPARKvue or PASCO Capstone to check for a firmware update.

SPARKvue

1. Turn on the Wireless EKG Sensor.
2. Open SPARKvue then click **Sensor Data**.
3. Select the sensor that matches the device ID.
4. If a notification appears, click **Yes** to update the firmware. If a notification doesn't appear, the firmware is up to date.

PASCO Capstone

1. Turn on the Wireless EKG Sensor.
2. Open Capstone then click **Hardware Setup**.
3. Select the sensor that matches the device ID.
4. If a notification appears, click **Yes** to update the firmware. If a notification doesn't appear, the firmware is up to date.

Using the sensor

Connect the sensor to a person

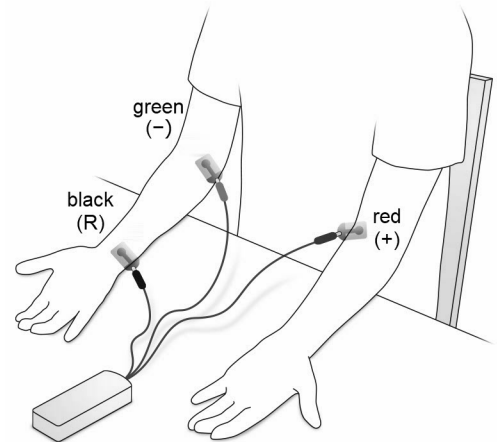



Figure 1. EKG leads attached to the electrodes.

1. Rub the skin at the locations shown in (Figure 1) with a paper towel to remove dead skin and oil. Shaving excess hair at these locations may provide better results.

 **Tip:** To help boost the EKG signal, apply a gel made from 100 mL of aloe gel mixed with 1 teaspoon of table salt.

2. Apply the adhesive electrode patches to the right wrist, right forearm just below the elbow, and left forearm just below the elbow. Press the patches firmly for best adhesion and signal quality.

 **CAUTION:** Placement of the electrode patches on the body provides an excellent path for current flow. Don't connect anything to the electrode patches other than the Wireless EKG Sensor.

3. Clip the EKG leads to the electrode patches as follows:

EKG LEAD	LOCATION
Green (-)	Right forearm
Black (R)	Right wrist
Red (+)	Left forearm

4. Arrange the leads so that they hang loosely without straining the patches.

Collect data

Connect the sensor to SPARKvue or Capstone to collect data.



SPARKvue

1. Turn on the sensor.
2. Open SPARKvue then click Sensor Data.



3. Select the that matches its device ID.
4. Under Quick Start Experiments, select **EKG and Heart Rate**.
5. Click Start ● to begin data collection.

PASCO Capstone

1. Turn on the sensor.
2. Open Capstone then click Hardware Setup .
3. Select the that matches its device ID. Click Hardware Setup  to close the panel.
4. Select the **EKG and Heart Rate** Quick Start Experiment.
5. Click Record ● to begin data collection.

Analyzing the electrocardiogram

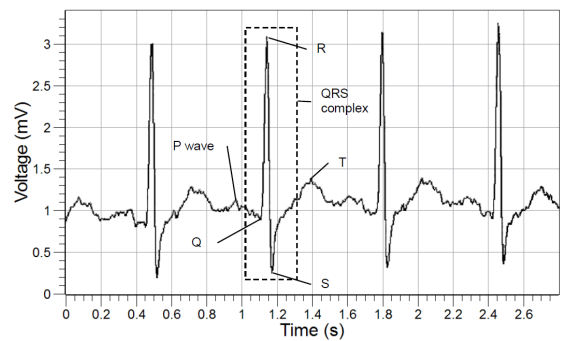

Figure 2. Example electrocardiogram.

The voltage versus time graph displays an electrocardiogram (Figure 2). One part of the electrocardiogram is a trace indicating no detectable electrical activity (flat line). This line is called the isoelectric line. Deviation from the isoelectric line indicates electrical activity of the heart muscles. The sensor's voltage measurement represents this deviation.

The first deviation from the isoelectric line is an upward pulse followed by a return to the isoelectric line. This is called the **P wave**. This wave is caused by the depolarization of the atria and is associated with the contraction of the atria.

After a return to the isoelectric line, there is a short delay while the heart's atrioventricular (AV) node depolarizes and sends a signal along the atrioventricular bundle of conducting fibers to the Purkinje fibers. The Purkinje fibers bring depolarization to all parts of the ventricles almost simultaneously.

After the AV node depolarizes there is a downward pulse called the **Q wave**. Shortly after the Q wave there is a rapid upswing of the line called the **R wave**. This is followed by a strong downswing of the line called the **S wave** and then a return to the isoelectric line. These three waves together are called the **QRS complex**. This complex is caused by the depolarization of the ventricles and is associated with the contraction of the ventricles.

After a short period the sodium and calcium ions that have been involved in the contraction migrate back to their original location in a process that involves potassium ions and the sodium-potassium pump. The movement of these ions generates an upward wave that then returns to the isoelectric line. This upward pulse is called the **T wave** and indicates repolarization of the ventricles.

The sequence from P wave to T wave represents one heart cycle. The number of such cycles in a minute is called the heart rate and is typically 70-80 cycles (or beats) per minute at rest.

Additional resources

Product information

Visit the product web page at pasco.com/product/PS-3236 for additional information including:

- Specifications
- Buying Guide
- Experiments
- Documents

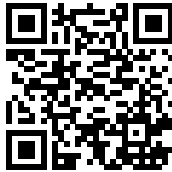

Software help

The SPARKvue and PASCO Capstone Help provide additional information on how to use the Wireless EKG Sensor with the software. Access the help within the software or online.

SPARKvue

Software: Click  then select Help.

Online: pasco.com/help/sparkvue

PASCO Capstone

Software: In the menu bar, click Help then select PASCO Capstone Help.

Online: pasco.com/help/capstone

Technical Support

Need more help? Our knowledgeable and friendly Technical Support staff is ready to provide assistance with this or any other PASCO product.

Phone (USA)	1-800-772-8700 (Option 4)
Phone (International)	+1 916 462 8384
Online	pasco.com/support

Regulatory information

Warranty, Copyright, and Trademarks

Limited Warranty

For a description of the product warranty, see the Warranty and Returns page at www.pasco.com/legal.

Copyright

This document is copyrighted with all rights reserved. Permission is granted to non-profit educational institutions for reproduction of any part of this manual, providing the reproductions are used only in their laboratories and classrooms, and are not sold for profit. Reproduction under any other circumstances, without the written consent of PASCO scientific, is prohibited.

Trademarks

PASCO and PASCO scientific are trademarks or registered trademarks of PASCO scientific, in the United States and/or in other countries. All other brands, products, or service names are or may be trademarks or service marks of, and are used to identify, products or services of, their respective owners. For more information visit www.pasco.com/legal.

Product end of life disposal instructions

 This electronic product is subject to disposal and recycling regulations that vary by country and region. It is your responsibility to recycle your electronic equipment per your local environmental laws and regulations to ensure that it will be recycled in a manner that protects human health and the environment. To find out where you can drop off your waste equipment for recycling, please contact your local waste recycle or disposal service, or the place where you purchased the product.

The European Union WEEE (Waste Electronic and Electrical Equipment) symbol on the product or its packaging indicates that this product must not be disposed of in a standard waste container.

Battery disposal instructions

 Batteries contain chemicals that, if released, may affect the environment and human health. Batteries should be collected separately for recycling and recycled at a local hazardous material disposal location adhering to your country and local government regulations. To find out where you can drop off your waste battery for recycling, please contact your local waste disposal service, or the product representative. The battery used in this product is marked with the European Union symbol for waste batteries to indicate the need for the separate collection and recycling of batteries.

CE statement

This device has been tested and found to comply with the essential requirements and other relevant provisions of the applicable EU Directives.

FCC statement

This device complies with part 15 of the FCC Rules. Operation is subject to the following two conditions: (1) This device may not cause harmful interference, and (2) this device must accept any interference received, including interference that may cause undesired operation.

MATERIAL SAFETY DATA SHEET
Tab Diagnostic EKG Electrodes –
Conductive Silver

1. PRODUCT AND COMPANY IDENTIFICATION

Product Name Tab Diagnostic EKG Electrodes – Conductive Silver
Use/Size Electrode Article used in Medical Application
Product Numbers 30788452, 30807732, 31433538, 31447793, 50000036, 50000044, 50000141, 50000145, 50097385, EB10001, EB10002, EF00041, EF00042, EF00046, EF00051, EF00052, EF00053, EF00054, EF00066, EF00071, EF00074, EF00075, EF00076, EF00078, EF00081, EF00082, EF00083, EF00091, EF00093, EF00094, EF00145, EF00149, EF00160, ER01000, ER01000A, ER01001, ER01002, ER01005, ER01033, ER88006, ER88007, ET88010
Manufacturer/Supplier Tyco Healthcare/Kendall
Address 15 Hampshire Street
Mansfield, MA 02048
Phone Number (508) 261-8000 (Monday – Friday 8:00 am to 5:00 pm)
Chemtrec Number (800) 424-9300
Revision Date: February 1, 2005
MSDS Date: February 1, 2005

This MSDS has been compiled in accordance with - EC Directive 91/155/EC - OSHA's Hazcom Standard (29 CFR 1910.1200)

2. COMPOSITION/INFORMATION ON THE COMPONENTS

Component Name	CAS#/Codes	Concentration	R Phrases	Classification
Electrode	Proprietary	100.0%	R-None	None

3. HAZARD IDENTIFICATION

<p>EU Main Hazards Not classified as hazardous.</p>
--

Routes of Entry

- Eye contact - Skin contact

Carcinogenic Status

Not considered carcinogenic by NTP, IARC, and OSHA.

Target Organs

- Eye - Skin

Health Effects - Eyes

Contact with electrode may cause slight transient irritation.

Health Effects - Skin

Electrode is non-irritating to skin.

Health Effects - Ingestion

No adverse effects are expected during normal conditions of use.

Health Effects - Inhalation

No adverse effects are expected during normal conditions of use.

MATERIAL SAFETY DATA SHEET
Tab Diagnostic EKG Electrodes –
Conductive Silver

4. FIRST AID MEASURES

Eyes

Immediately flood the eye with plenty of water for at least 15 minutes, holding the eye open. Obtain medical attention if soreness or redness persists.

Skin

Wash skin thoroughly with soap and water. Continue washing for at least 15 minutes. Remove contaminated clothing as washing proceeds. Obtain medical attention if blistering occurs or redness persists.

Ingestion

If article is accidentally swallowed, seek medical attention immediately.

Inhalation

Inhalation hazard is not possible with this article.

Advice to Physicians

Treat symptomatically.

5. FIRE FIGHTING MEASURES

Extinguishing Media

Not Flammable. Select extinguishing agent appropriate to other materials involved.

Unusual Fire and Explosion Hazards

This product may give rise to hazardous fumes in a fire.

Protective Equipment for Fire-Fighting

Wear full protective clothing and self-contained breathing apparatus.

6. ACCIDENTAL RELEASE MEASURES

This article should be picked up or sweep up and disposed of as solid waste.

7. HANDLING AND STORAGE

Wear appropriate personal protective equipment when handling. Storage area should be: - cool - dry

8. EXPOSURE CONTROLS/PERSONAL PROTECTION

Occupational Exposure Standards

Exposure limits are listed below, if they exist.

Electrode

None assigned.

Engineering Control Measures

No specific controls are necessary.

Respiratory Protection

Respiratory protection is not required.

Hand Protection

Protective gloves.

Eye Protection

Chemical goggles or safety glasses with side shields may be worn.

MATERIAL SAFETY DATA SHEET
Tab Diagnostic EKG Electrodes –
Conductive Silver

Body Protection
Normal work wear.

9. PHYSICAL AND CHEMICAL PROPERTIES

Physical State	Solid article
Color	Various
Odor	Odorless
pH	Approximately 3 - 5 (based on conductive salt contained within)
Specific Gravity	Not applicable
Boiling Range/Point (°C/F)	Not applicable
Melting Point (°C/F)	Not applicable
Flash Point (PMCC) (°C)	Not applicable
Vapor Pressure	Negligible
Solubility in Water	Completely insoluble
Vapor Density (Air = 1)	Not applicable
Evaporation Rate	Not applicable
VOC (g/l)	0.0

10. STABILITY AND REACTIVITY

Stability

Stable under normal conditions.

Conditions to Avoid

- Contact with incompatible materials

Materials to Avoid

- Strong oxidizing agents - Strong Bases

Hazardous Polymerization

Will not occur.

Hazardous Decomposition Products

- oxides of carbon – oxides of silver – oxides of tin - hydrogen chloride

11. TOXICOLOGICAL INFORMATION

Acute Toxicity

(Electrode) Primary skin irritation (modified Draize testing) was non-irritating.

(Electrode) This article has tested negative for skin sensitization by Buehler Patch testing.

(Electrode) USP Agar Diffusion testing has shown this article to be non-cytotoxic.

Chronic Toxicity/Carcinogenicity

This product is not expected to cause long term adverse health effects.

Genotoxicity

This product is not expected to cause any mutagenic effects.

Reproductive/Developmental Toxicity

This product is not expected to cause reproductive or developmental health effects.

MATERIAL SAFETY DATA SHEET
Tab Diagnostic EKG Electrodes –
Conductive Silver

12. ECOLOGICAL INFORMATION

Mobility

No relevant studies identified.

Persistence/Degradability

No relevant studies identified.

Bio-accumulation

No relevant studies identified.

Ecotoxicity

No relevant studies identified

13. DISPOSAL

Dispose of in accordance with all applicable local and national regulations.

14. TRANSPORT INFORMATION

DOT CFR 172.101 Data	Not Regulated
UN Proper Shipping Name	Not Regulated
UN Class	None.
UN Number	None.
UN Packaging Group	None.
Classification for AIR Transportation (IATA)	Consult current IATA Regulations prior to shipping by air.

15. REGULATORY INFORMATION

EU Label Information

Classification and labelling have been performed according to EU directives 67/548/EEC and 99/45/EC including amendments.

EU Hazard Symbol and Indication of Danger

According to EC Commission Directive 67/548/EEC this product is not classified.

R phrases

None.

S phrases

None.

US REGULATIONS (Federal, State) and INTERNATIONAL CHEMICAL REGISTRATION LAWS**TSCA Listing**

This product contains ingredients that are listed on or exempt from listing on the EPA Toxic Substance Control Act Chemical Inventory.

EINECS Listing

All ingredients in this product are listed on the European Inventory of Existing Commercial Chemical Substances (EINECS) or are exempt from listing.

DSL (Canadian) Listing

All ingredients in this product are listed on or exempted from listing on the Domestic Substance List (DSL).

MATERIAL SAFETY DATA SHEET
Tab Diagnostic EKG Electrodes –
Conductive Silver

WHMIS Classification

This article is exempt under WHMIS.

This product was classified in accordance with the hazard criteria of the Canadian Controlled Products Regulations and the MSDS contains all the information required by these regulations.

MA Right To Know Law

This product and its components are exempt from the requirements of the Massachusetts Right To Know Substance List.

PA Right To Know Law

This product and its components are exempt from the requirements of the Pennsylvania Hazardous Substance List.

NJ Right To Know Law

This product and its components are exempt from the requirements of the New Jersey Workplace Hazardous Substance List.

California Proposition 65

This product contains no chemicals that have been found by the State of California to cause cancer, birth defects or other reproductive harm.

SARA Title III Sect. 302 (EHS)

This product does not contain any chemicals subject to SARA Title III Section 302.

SARA Title III Sect. 304

This product does not contain any chemicals subject to SARA Title III Section 304.

SARA Title III Sect. 311/312 Categorization

Immediate (Acute) Health Hazard

SARA Title III Sect. 313

This product and its components are exempt from the requirements of Section 313.

16. OTHER INFORMATION

NFPA Ratings

NFPA Code for Flammability - 0

NFPA Code for Health - 0

NFPA Code for Reactivity - 0

NFPA Code for Special Hazards - 0

HMIS Ratings

HMIS Code for Flammability - 0

HMIS Code for Health - 0

HMIS Code for Reactivity - 0

HMIS Code for Personal Protection - See Section 8

16. OTHER INFORMATION

Abbreviations

N/A: Denotes no applicable information found or available

CAS#: Chemical Abstracts Service Number

ACGIH: American Conference of Governmental Industrial Hygienists

OSHA: Occupational Safety and Health Administration

TLV: Threshold Limit Value

MATERIAL SAFETY DATA SHEET
Tab Diagnostic EKG Electrodes –
Conductive Silver

PEL: Permissible Exposure Limit
STEL: Short Term Exposure Limit
NTP: National Toxicology Program
IARC: International Agency for Research on Cancer
R: Risk
S: Safety
LC50: Lethal Concentration 50%
LD50: Lethal Dose 50%
BOD: Biological Oxygen Demand
KoC: Soil Organic Carbon Partition Coefficient

Prepared By: EnviroNet LLC.

The information and recommendations presented in this MSDS are based on sources believed to be accurate; therefore, Tyco Healthcare/Kendall Company assumes no liability for the accuracy or completeness of this information. It is the user's responsibility to determine the suitability of the information for their particular purposes.

Wireless Heart Rate Module

PS-3566

Wireless Hand Grip Heart Rate Sensor

PS-3206

Wireless Exercise Heart Rate Sensor

PS-3207



PS-3566 Wireless Heart Rate Module

PS-3564 Wireless Exercise Heart Rate Strap

PS-3565 Wireless Hand Grips

PS-3207 Wireless Exercise Heart Rate Sensor

PS-3206 Wireless Hand Grip Heart Rate Sensor

For Educational Use Only! Note: These are not medical devices. They are designed for educational use only and should not be used in any medical process such as life support or patient diagnosis. They are also not intended for use in graduate research or industry including industrial control or any type of industrial testing.

Item	Model	Included Items	Model
Wireless Hand Grip Heart Rate Sensor (See page 3)	PS-3206	Wireless Heart Rate Module Wireless Heart Rate Hand Grips	PS-3566 PS-3565
Wireless Exercise Heart Rate Sensor (See page 7)	PS-3207	Wireless Heart Rate Module Wireless Exercise Heart Rate Strap	PS-3566 PS-3564

Introduction

The PS-3566 Wireless Heart Rate Module is included with the PS-3206 Wireless Hand Grip Heart Rate Sensor and the PS-3207 Wireless Exercise Heart Rate Sensor. The PS-3206 Wireless Hand-Grip Heart Rate Sensor consists of the Wireless Heart Rate Module and the PS-3565 Heart Rate Hand Grips. The PS-3207 Wireless Exercise Heart Rate Sensor consists of the Wireless Heart Rate Module and the PS-3564 Exercise Heart Rate Strap.

Software Required

The Wireless Heart Rate Module connects to a computer, smart phone, or tablet via Bluetooth using the PASCO Data Collection Software, **PASCO Capstone** or **SPARKvue**. See the PASCO web site at:

www.pasco.com/downloads

for information about the latest software.

Wireless Heart Rate Module

The module uses a CR2025 battery with an expected usage time of two years (assuming one hour of use per day). The module is water resistant but it is not intended to be used under water. Bluetooth transmission will not work under water. The module has a two year warranty provided by the manufacturer.

Battery

To change the battery, follow these steps.

1. Use a coin to open the battery cover by turning it counterclockwise (to OPEN).
2. Use a small flat blade screwdriver to remove the old battery. Insert the new battery (CR2025) inside the cover with the positive (+) side against the battery cover.
3. Make sure that the "O-ring" that seals the cover is seated in the sealing groove to ensure water resistance.
4. Use the coin to turn the cover clockwise to CLOSE.

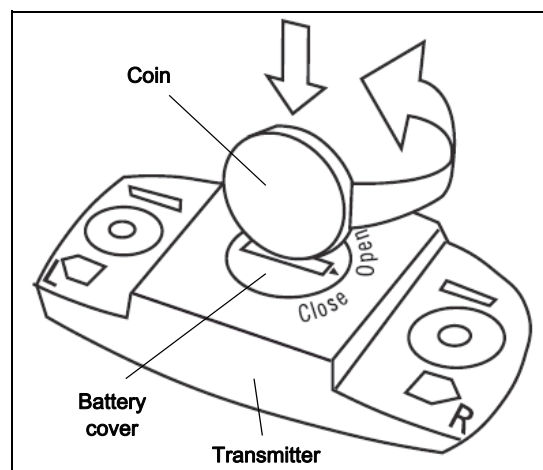

NOTE: The module is water resistant, but Immersing it in water will block the Bluetooth transmission. Therefore, it is not recommended for you to use the module in water.

For more information, see the web page at:

https://support.polar.com/us-en/support/H7_heart_rate_sensor

Wireless Hand Grip Heart Rate Sensor (PS-3206)

NOTE: Remove the protective tape from the metallic strips on the front and back of each grip before using.

Snap the Wireless Heart Rate Module onto the connectors near the top of the slightly longer hand grip.

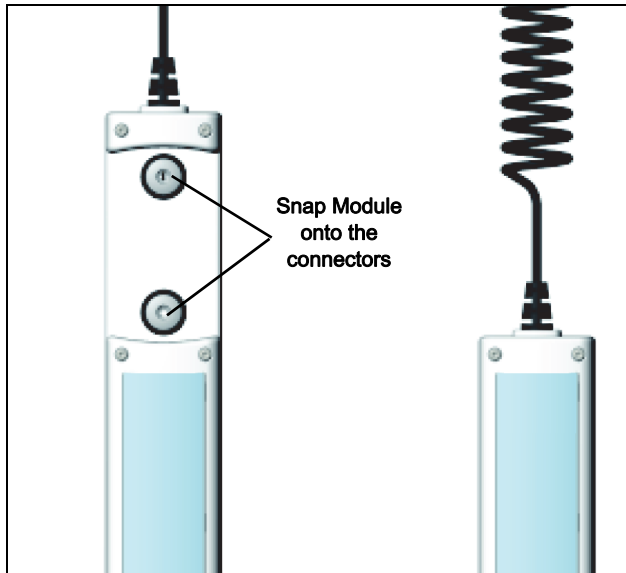

Heart rate is a basic body measurement that can be used to investigate the cardiovascular system and its response to stimulus (exercise, stress, etc.) during relatively simple experiments. The Wireless Hand Grip Heart Rate Sensor can be used to measure heart rate between 0 and 240 beats per minute (bpm) during mild exercise or periods of rest. **NOTE:** The sensor is not a medical instrument. It cannot be used to gauge the health or fitness of a person.

The coiled cable between the two hand-held grips enables users with different shoulder widths to use the sensor comfortably. The grips are designed for a wide range of hand sizes (8 years old to adult).

Measurement Technique

Grasp the hand grips firmly but not too tightly in the palms of the hands so that one of the metallic strips on each grip is in the center of the palm. Measurements will be easier and more accurate if the hands are clean and dry.

Theory of Operation

Like an electrocardiograph (EKG) that monitors the electrical signal of the heart, the Hand-Grip Heart Rate

Sensor measures electrical signals that start at the heart and reach the skin at the palms of the hands.

Sampling

By default, the Wireless Hand-Grip Heart Rate Sensor continuously monitors the time between beats, calculates the beats per minute, and averages the beats per minute within a five second interval. The average is then displayed. This process tends to “smooth” the collected data.

Specifications

Sensor Range	0 to 240 beats per minute
Accuracy	± 1 beat per minute
Resolution	1 beat per minute
Maximum Sample Rate	1 per two seconds
Default Sample Rate	1 per five seconds

Operation

Software Help

NOTE: See the SPARKvue Help or PASCO Capstone Help for information about collecting, displaying, and analyzing data.

- In SPARKvue, select the HELP button in any screen including the Home Screen.
- In PASCO Capstone, select PASCO Capstone Help from the Help menu, or press F1.

Connect the Sensor Wirelessly

Start the PASCO data collection software (such as PASCO Capstone or SPARKvue).

Setup the PASCO Capstone Software

Hold the hand grips firmly in the center of your palms.

PASCO Capstone: Select “Hardware Setup” in the Tools palette.

- The sensors are ordered by proximity to the device.
- In the Hardware Setup window, select the sensor that has the alpha-numeric device ID for the “Polar” module.

- After the module and the software connect, the icon and name of the sensor will appear in the Hardware Setup window.

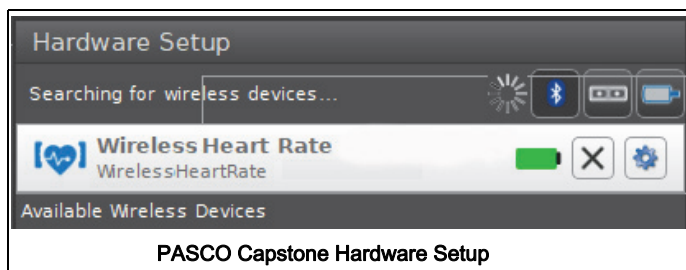

Close the Hardware Setup window.

Collect Data

In **PASCO Capstone**, select one of the QuickStart template displays in the main window or click one Display palette. In the display, use the <Select Measurement> menu to pick a measurement to be shown.

Select **Record** to begin collecting data. Click **Stop** to end collecting data.

Setup the SPARKvue Software

Hold the hand grips firmly in the center of your palms.

SPARKvue: In the Home screen, select the “Bluetooth” icon at the top of the screen. The Wireless Devices window opens.

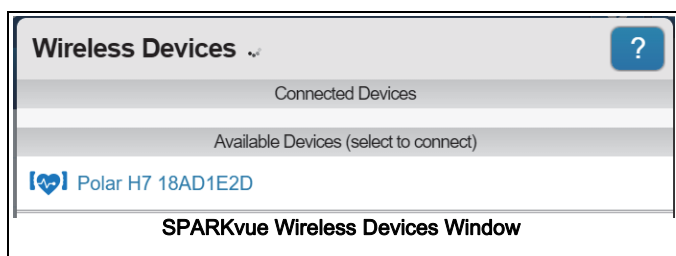

- The sensors are ordered by proximity to the device.
- Select the sensor that has the alpha-numeric device ID for the “Polar” module.
- Select **Done**. A list of measurements appears under the sensor in the Home Screen.

Collect Data

- In the SPARKvue Home Screen, select a measurement such as heart rate (bpm) from the list under the sensor’s name. A graph of the measurement versus time opens.

- In SPARKvue, select the **Start** button to begin collecting data.

Care and Maintenance

Remove the Wireless Heart Rate Monitor from the Hand Grips when the sensor is not in use.

Clean the hand grips after each use with a damp cloth or paper towel. The hand grips can be cleaned with anti-bacterial cleaners. Do not submerge the hand grips in water.

Signal Loss and Electrical Interference

- Erratic measurements or large reading fluctuations (e.g., drop to 0 beats per minute (bpm) or sudden increase to 240 bpm) usually indicate signal loss.
- The most common cause of signal loss is loss of contact between the hands and the hand grips. Keep the hand grips in the palms of both hands.
- If signal loss occurs, check the software and the position of the hands on the hand grips. If necessary, restart the software.
- Avoid computer monitors, magnets, power cords, television sets, or other appliances that emit electromagnetic radiation.

Heart Rate Activity Suggestions

Sit in a chair. Start collecting data. Record your resting heart rate for 60 seconds.

Stand up. Jog in place for three to five minutes and continue to collect data.

Stop running but continue to collect data for another five minutes. After five minutes, stop collecting data.

Use the software to graph your data. Compare your resting heart rate to your heart rate during exercise and during the five minute recovery time after exercise.

Recommended Exercise Heart Rate Levels

Age (yrs.)	Max. Heart Rate (bpm)*	Min. Training Threshold**	Max. Training Threshold***
15	205	123	185
20	200	120	180
25	195	117	176
30	190	114	171

*Maximum estimated heart rate is $220 - \text{age (years)}$.

**Minimum training threshold is equal to 60% of the maximum heart rate.

***Maximum training threshold is equal to 90% of the maximum heart rate.

Ranges are based on the American College of Sports Medicine recommendations for healthy individuals. Ranges will vary.

NOTE: The Wireless Hand Grip Heart Rate Sensor is NOT a diagnostic tool.

Wireless Exercise Heart Rate Sensor (PS-3207)

The Wireless Exercise Heart Rate Sensor uses the Wireless Heart Rate Module mounted on the Wireless Exercise Heart Rate Strap. It measures heart rates from 0 to 240 bpm. The sensor can measure the heart rate during exercise without a cable getting in the way because the sensor transmits wirelessly via Bluetooth to the PASCO Data Collection Software.

The module snaps onto the strap and the strap wraps around your chest with the module positioned over the center of the chest. The software averages the heart rate in five second intervals.

Wearing the Exercise Heart Rate Strap

The strap has an electrode area on the underside that detects electrical signals from the cardiac muscle.

1. Wet the electrode area with water and make sure that it is well moistened.

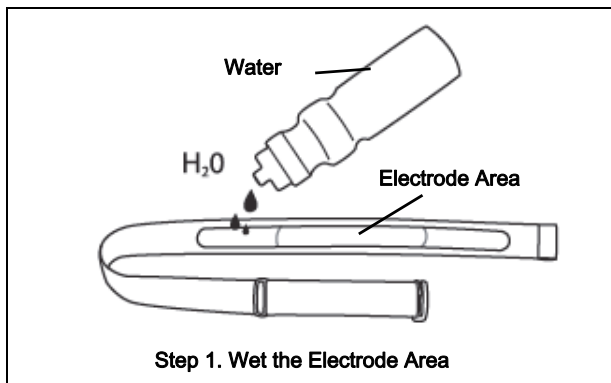

2. Attach the Wireless Heart Rate Module to the connector snaps on the front side of the strap.

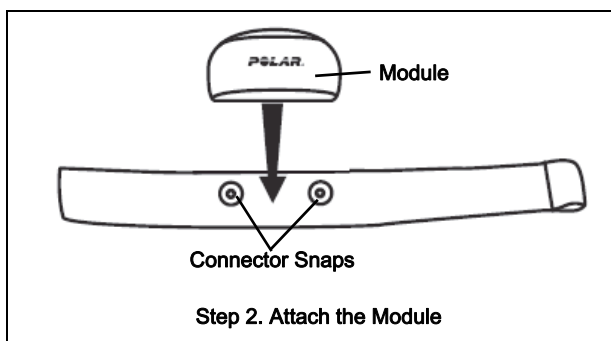

3. Adjust the strap length to fit snugly and comfortably around your chest just below the chest muscles.

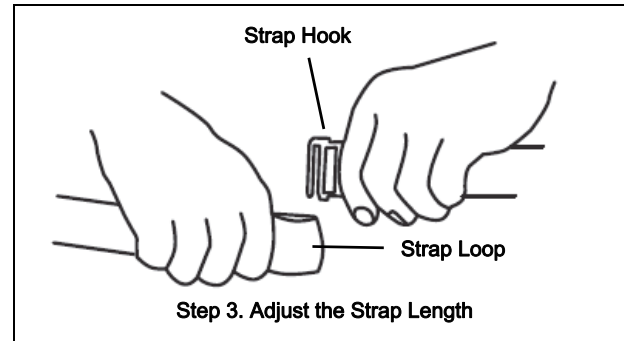

Transmitter Strap Options

Option One - Under a Shirt: Follow steps 1, 2, and 3 above. Put the strap around your chest and connect the strap hook to the loop in the other end of the strap. Make sure that the wet electrode areas are firmly against your skin and that the module is in a central location and the Polar logo on the transmitter is upright (see Option One).

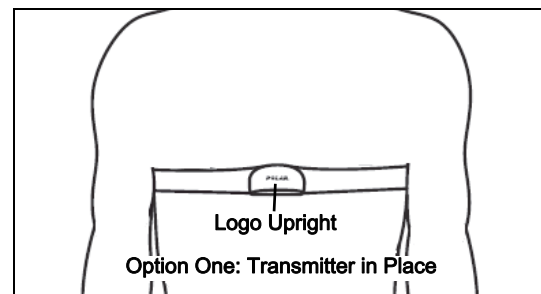

Option Two - Over a Shirt: To use the sensor over the top of a T-shirt or tank top, follow steps 1, 2, and 3 above. Put the strap around your chest on top of the shirt and connect the strap hook to the loop. Then, wet the shirt beneath the electrode areas of the strap so that the shirt and the skin beneath the shirt are well moistened.



Option Three - Hold in Both Hands: Wet the electrode area and connect the module to the strap, but hold the strap with both hands so that the palm area of each hand touches the wet electrode area. [NOTE: With this option, the data quality may vary.]

Specifications

Sensor Range	0 to 240 beats per minute
Accuracy	± 1 beat per minute
Resolution	1 beat per minute
Maximum Sample Rate	1 per two seconds
Default Sample Rate	1 per five seconds

Operation

Software Help

NOTE: See the SPARKvue Help or PASCO Capstone Help for information about collecting, displaying, and analyzing data.

- In SPARKvue, select the HELP button in any screen including the Home Screen.
- In PASCO Capstone, select PASCO Capstone Help from the Help menu, or press F1.

Connect the Sensor Wirelessly

Start the PASCO data collection software (such as PASCO Capstone or SPARKvue).

Setup the PASCO Capstone Software

Wet the electrode area and put the strap around your chest.

PASCO Capstone: Select “Hardware Setup” in the Tools palette.

- The sensors are ordered by proximity to the device.
- In the Hardware Setup window, select the sensor that has the alpha-numeric device ID for the “Polar” module.

- After the module and the software connect, the icon and name of the sensor will appear in the Hardware Setup window.

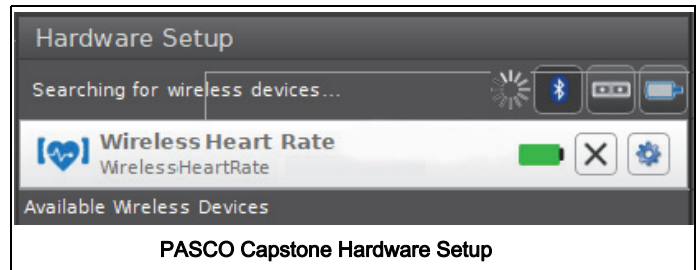

Close the Hardware Setup window.

Collect Data

In **PASCO Capstone**, select one of the QuickStart template displays in the main window or click one Display palette. In the display, use the <Select Measurement> menu to pick a measurement to be shown.

Select **Record** to begin collecting data. Click **Stop** to end collecting data.

Setup the SPARKvue Software

Wet the electrode area and put the strap around your chest.

SPARKvue: In the Home screen, select the “Bluetooth” icon at the top of the screen. The Wireless Devices window opens.

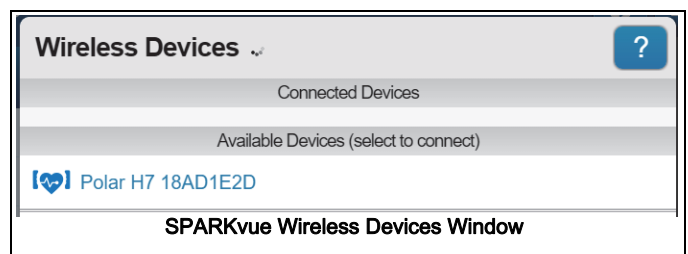

- The sensors are ordered by proximity to the device.
- Select the sensor that has the alpha-numeric device ID for the “Polar” module.
- Select **Done**. A list of measurements appears under the sensor in the Home Screen.

Collect Data

- In the SPARKvue Home Screen, select a measurement such as heart rate (bpm) from the list

under the sensor's name. A graph of the measurement versus time opens.

- In SPARKvue, select the Start button to begin collecting data.

Care and Maintenance

Remove the Wireless Heart Rate Monitor from the strap when the sensor is not in use.

Clean the strap thoroughly after each use. Washing instructions can be found on the fabric tab at the hook end of the strap.

Signal Loss and Electrical Interference

- Erratic measurements or large reading fluctuations (e.g., drop to 0 beats per minute (bpm) or sudden increase to 240 bpm) usually indicate signal loss.
- The most common cause of signal loss is loss of contact with the electrode area. Keep the electrode area moist.
- If signal loss occurs, check the software and the position of the strap. If necessary, restart the software.
- Avoid computer monitors, magnets, power cords, television sets, or other appliances that emit electromagnetic radiation.

Heart Rate Activity Suggestions

Sit in a chair. Start collecting data. Record your resting heart rate for 60 seconds.

Stand up. Jog in place for three to five minutes and continue to collect data.

Stop running but continue to collect data for another five minutes. After five minutes, stop collecting data.

Use the software to graph your data. Compare your resting heart rate to your heart rate during exercise and during the five minute recovery time after exercise.

Recommended Exercise Heart Rate Levels

Age (yrs.)	Max. Heart Rate (bpm)*	Min. Training Threshold**	Max. Training Threshold***
15	205	123	185
20	200	120	180
25	195	117	176
30	190	114	171

*Maximum estimated heart rate is $220 - \text{age (years)}$.

**Minimum training threshold is equal to 60% of the maximum heart rate.

***Maximum training threshold is equal to 90% of the maximum heart rate.

Ranges are based on the American College of Sports Medicine recommendations for healthy individuals. Ranges will vary.

NOTE: The Wireless Exercise Heart Rate Sensor is NOT a diagnostic tool.

Experiment Suggestions

- Heart rate, respiration, and skin temperature during exercise.
- Effect on exercise heart rate for various forms of exercise (e.g., aerobic vs. anaerobic).
- Exercise recovery rates for individuals with different fitness.
- Exercise heart rate in healthy and diseased populations.

Sample Data: Heart Rate Changes During and After Exercise

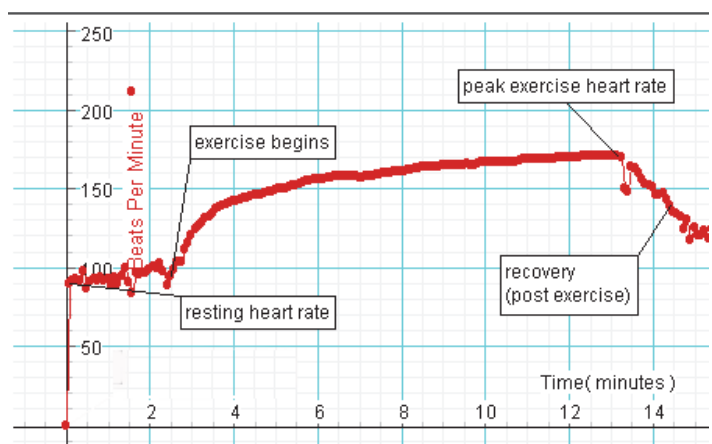

General Information

Battery Life

Battery Usage

Battery life is very important to making the Wireless Heart Rate Module always ready to use.

Maximizing Battery Life

One of the factors that affects battery life is the storage temperature. Therefore, avoid storing the Wireless Heart Rate Module in very cold or very hot environments.

Replacement Items

Replacement items are:

- PS-3566 Wireless Heart Rate Module
- PS-3565 Wireless Heart Rate Hand Grips
- PS-3564 Wireless Exercise Heart Rate Strap

Technical Support

For assistance with any PASCO product, contact PASCO at:

Address: PASCO scientific
10101 Foothills Blvd.
Roseville, CA 95747-7100

Phone: +1 916 462 8384 (worldwide)
8700-772-8700 (U.S.)

Web: www.pasco.com/support

Email: support@pasco.com

The Reference Guide will be updated periodically. For the latest revision of this Reference Guide, visit the PASCO Web site at

www.pasco.com/manuals

and enter the product number (e.g., PS-3566) in the text window.

Limited Warranty

For a description of the product warranty, see the PASCO catalog. For more information visit www.pasco.com/legal

Copyright

This PASCO scientific *Reference Guide* is copyrighted with all rights reserved. Permission is granted to non-profit educational institutions for reproduction of any part of this manual, providing the reproductions are

used only in their laboratories and classrooms, and are not sold for profit. Reproduction under any other circumstances, without the written consent of PASCO scientific, is prohibited. Version 23-07-2016.

Trademarks

PASCO, PASCO scientific, PASCO Capstone, and SPARKvue are trademarks or registered trademarks of PASCO scientific, in the United States and/or in other countries. All other brands, products, or service names are or may be trademarks or service marks of, and are used to identify, products or services of their respective owners. For more information visit www.pasco.com/legal.

FCC Statement

This Class B digital device complies with part 15 of the FCC Rules. Operation is subject to the following two conditions: (1) This device may not cause harmful interference, and (2) this device must accept any interference received, including interference that may cause undesired operation.

CE Statement

This device has been tested and found to comply with the essential requirements and other relevant provisions of the applicable EU Directives.

Product End of Life Disposal Instructions:

This electronic product is subject to disposal and recycling regulations that vary by country and region. It is your responsibility to recycle your electronic equipment per your local environmental laws and regulations to ensure that it will be recycled in a manner that protects human health and the environment. To find out where you can drop off your waste equipment for recycling, please contact your local waste recycle/disposal service, or the place where you purchased the product.

The European Union WEEE (Waste Electronic and Electrical Equipment) symbol (to the right) and on the product or its packaging indicates that this product must not be disposed of in a standard waste container.



Battery Disposal Instructions:

Batteries contain chemicals that, if released, may affect the environment and human health. Batteries should be collected separately for recycling, and recycled at a local hazardous material disposal location adhering to your country and local government regulations. To find out where you can drop off your waste battery for recycling, please contact your local waste disposal service, or the product representative..

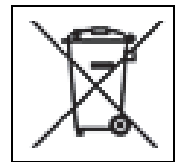

Wireless Spirometer

PS-3234

Note: This is not a medical device. It is designed for educational use only and should not be used in any medical process such as life support or patient diagnosis. It is also not intended for use in graduate research or industry including industrial control or any type of industrial testing.

Note: Read the instructions before using this product. Students should be supervised by their instructors. When using this product, follow the instructions in this manual and all local safety guidelines that apply to you.

Note: Do not share mouthpieces or filters. The mouthpieces and filters are intended for a single-use occasion, which may include several tests with the same individual.

CAUTION: In medical settings, pulmonary function tests are performed under the supervision of a medical professional. When using a spirometer without medical supervision, use extra caution. A person with a medical condition that may be affected by a pulmonary function test should not use the PASCO Spirometer. Discontinue use if the subject encounters breathing difficulty or discomfort.

What's included

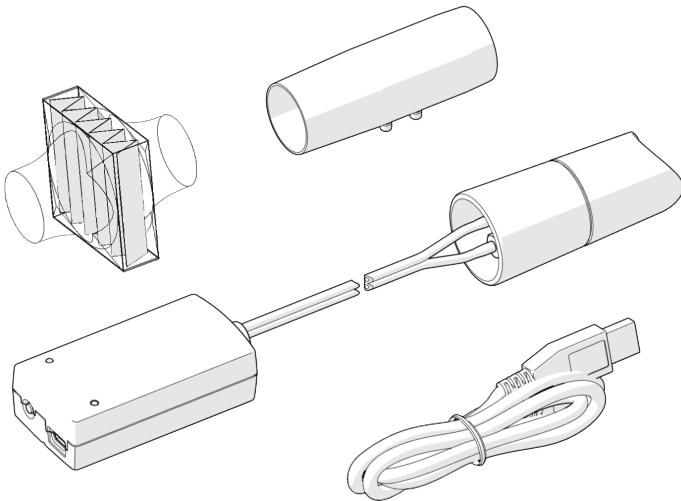

- Wireless Spirometer
- 3× Mouthpiece
- 3× Mouthpiece Filter
- USB Cable

Features

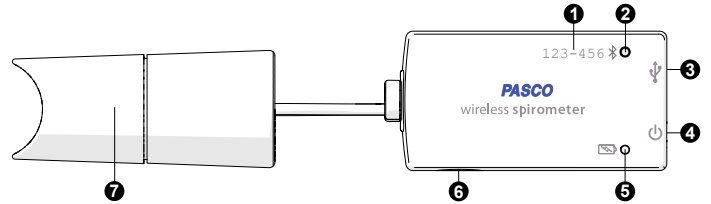

1. **Device ID**
Use to identify the sensor when connecting using Bluetooth.

2. **Bluetooth Status Light** 
Indicates the status of the Bluetooth connection.

LIGHT	STATUS
Red, blink	Ready to pair
Green, blink	Paired
Yellow, blink	Remotely logging data

3. **USB Port** 
Use with the USB cable to connect to a USB wall charger to charge the battery. Also use to send measurement data to software when connected to a USB port of a computer or mobile device (iOS devices not supported).

4. **Power Button** 
Press and hold for one second to turn the sensor on or off.

5. **Battery Status Light** 
Indicates the battery level and charging status.



LIGHT	STATUS
Red, blink	Low battery level
Green, solid	Fully charged
Yellow, solid	Charging

6. **Threaded Hole**
Use for mounting the sensor, such as to a mounting rod. Accepts 1/4-in-20 screws.

7. **Handle**
Attach the mouthpiece to the handle. Hold the handle upright and steady while collecting data.

Getting started

Charge the battery

Connect the Wireless Spirometer USB port  to a USB charger using the included USB cable. The battery light  displays yellow while charging and changes to green when fully charged.

Get the software

You can use the Wireless Spirometer with SPARKvue or PASCO Capstone software. If you're not sure which app to use, visit [pasco.com/products/guides/software-comparison](https://www.pasco.com/products/guides/software-comparison) for help. SPARKvue is available as a free app for Chromebook, iOS, and Android devices. We offer a free trial of SPARKvue and Capstone for Windows and Mac.

WINDOWS AND MAC

CHROMEBOOK, iOS, AND ANDROID

Go to [pasco.com/downloads](https://www.pasco.com/downloads).

Search for **SPARKvue** in your device's app store.

If you already have the software, check that you have the latest update installed:

SPARKvue

Go to the **Main Menu**  then select **Check for Updates**.

PASCO Capstone

In the menu bar, click **Help** then select **Check for updates**.

Connect to the software

SPARKvue

1. Press and hold the power button  until the lights turn on.
2. Open SPARKvue.
3. Select **Sensor Data** on the Welcome Screen.



4. Select the Wireless Spirometer that matches its device ID.

 092-746 Spirometer

 **Important:** You may be prompted to update the firmware if a new version is available. If so, click **Yes** to update the firmware.

5. Select the measurements you want to display. **Lung Volume** is selected by default.
6. Select a template to display the data.

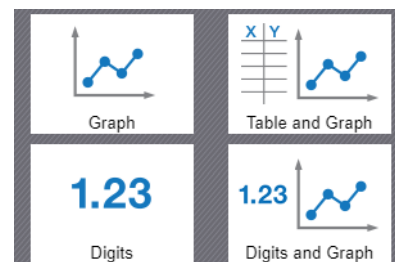



PASCO Capstone

1. Press and hold the power button  until the lights turn on.
2. Open PASCO Capstone.
3. Click **Hardware Setup**.



4. Select the Wireless Spirometer that matches its device ID.

 092-746 Spirometer

 **Important:** You may be prompted to update the firmware if a new version is available. If so, click **Yes** to update the firmware.

5. Click **Hardware Setup** again to close the panel.
6. Click **Sensor Data** to display a graph of Lung Volume versus Time.

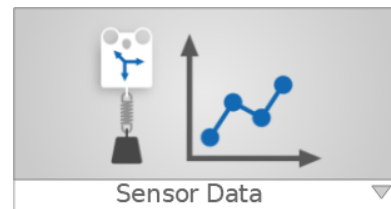

Set up and collect data

Using the sensor requires two people: one to serve as the test subject and one to perform data collection.

1. Connect the mouthpiece to the handle, making sure to align the pin on the mouthpiece with the notch on the handle. Connect the filter to the mouthpiece so that it creates a snug fit.

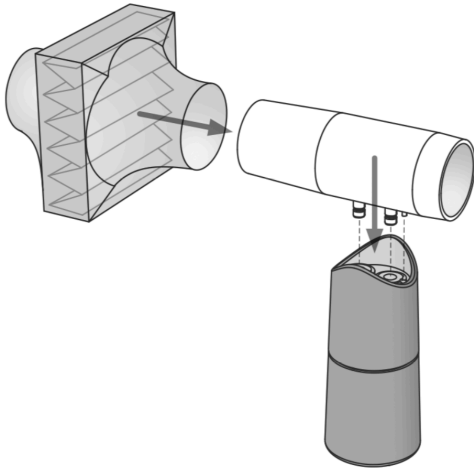

2. Tell the subject to hold their breath, place teeth and lips on the filter, pinch their nose closed, stand still, and relax.

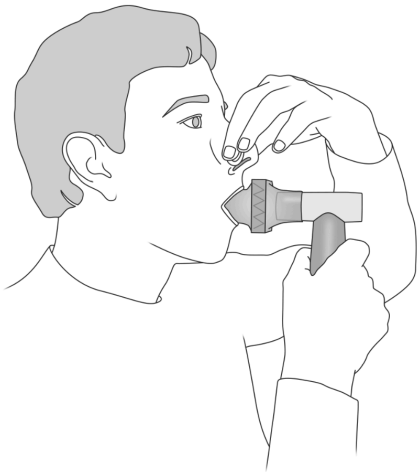

3. Start data collection. The sensor performs a calibration procedure which is indicated by the Bluetooth light flashing red. Proceed to the next step when the light flashes green.
4. Talk the test subject through each of the following data collection steps. Do not allow the test subject to see the data as it's collected.
 - a. Take four normal breaths.
 - b. Inhale as deeply as possible, then exhale deeply with maximum effort.
 - c. Take two normal breaths.
5. Stop data collection.

Note: You may need to run the test a few times to get satisfactory data.

Interpretation of the data

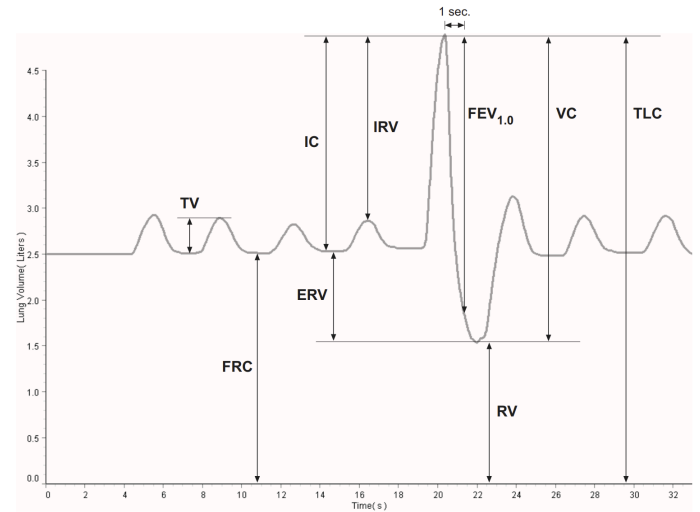

Tidal Volume (TV)

This is the volume of one breath or the amount of air moved into and out of the lungs during normal breathing.

Functional Residual Capacity (FRC)

This is the amount of air left in the lungs after a normal expiration ($FRC = RV + ERV$). A typical FRC is around 2.5 liters.

Inspiratory Capacity (IC)

This is the maximum amount of air that can be inspired after a normal expiration ($IC = TV + IRV$).

Expiratory Reserve Volume (ERV)

This is the amount of air moved out of the lungs during a forced expiration, beyond the level of tidal expiration.

Inspiratory Reserve Volume (IRV)

This is the amount of air moved into the lungs during a forced inspiration, beyond the level of tidal inspiration.

Forced Expiratory Volume in One Second (FEV_{1.0})

This is the volume of air moved out of the lungs in the first second of a forceful expiration following a maximal inspiration.

Residual Volume (RV)

This is the amount of air remaining in the lungs at the end of a forced expiration. A typical RV is around 1.2 L.

Vital Capacity (VC)

This is the maximum movable amount of air contained by the lungs ($VC = TV + IRV + ERV$).

Total Lung Capacity (TLC)

Maximum volume of air the lungs hold at peak forced inhalation.

Troubleshooting

In your graphs of Total Flow and Lung Volume, you may notice a slow drift or slight fluctuation in the baseline. These can be eliminated, in most cases, as described below. Note that slow baseline changes usually do not significantly affect the measurements of volumes and capacities that you take from the graphs.

- Air pressure changes in the environment during the measurement period can influence the sensor readings. Sources of such pressure changes include doors opening or closing, ventilation systems starting or stopping, and air movement within the testing room. In most cases, environmental pressure variation is tolerably low over the typical 30-second test period.
- The sensor calculates Total Flow by integrating the measured Flow Rate over time. Because of this time integration, a very small offset in the Flow Rate measurement may result in a noticeable upward or downward trend in the baseline of the Total Flow (or Lung Volume) data. This trend usually does not have a significant effect on the volume and capacity measurements taken from the graph, since each measurement is made between two data points recorded within a few seconds. In the data collection software you can eliminate the trend with this calculation: Total Flow = $\text{integral}((1 - \text{inrange}(0, .03, \text{abs}(\text{smooth}(10, R)))) * R)$
- Define R as the Flow Rate. Use the calculated data in place of the data directly from the sensor. If the trend is still apparent, increase the “.03” parameter so that it is slightly larger than the Flow Rate offset.

Download an experiment

Download one of several student-ready activities from the PASCO Experiment Library. Experiments include editable student handouts and teacher notes. Go to pasco.com/freelabs/ps-3232.

If you want to explore on your own, check out the SPARKvue and PASCO Capstone help guides to search for specific topics.

SPARKvue

Software: Go to the **Main Menu**  then select **Help**.

Online: pasco.com/help/sparkvue

PASCO Capstone

Software: In the menu bar, click **Help** then select **PASCO Capstone Help**.

Online: pasco.com/help/capstone

Specifications and accessories

Visit the product page at pasco.com/product/PS-3234 to view the specifications and explore accessories. Experiment files and support documents can also be found on the product page.

Technical Support

Need more help? Our knowledgeable and friendly Technical Support staff is ready to provide assistance with this or any other PASCO product.

Phone (USA)	1-800-772-8700 (Option 4)
Phone (International)	+1 916 462 8384
Online	pasco.com/support

Regulatory information

Warranty, Copyright, and Trademarks

Limited Warranty

For a description of the product warranty, see the Warranty and Returns page at www.pasco.com/legal.

Copyright

This document is copyrighted with all rights reserved. Permission is granted to non-profit educational institutions for reproduction of any part of this manual, providing the reproductions are used only in their laboratories and classrooms, and are not sold for profit. Reproduction under any other circumstances, without the written consent of PASCO scientific, is prohibited.

Trademarks

PASCO and PASCO scientific are trademarks or registered trademarks of PASCO scientific, in the United States and/or in other countries. All other brands, products, or service names are or may be trademarks or service marks of, and are used to identify, products or services of, their respective owners. For more information visit www.pasco.com/legal.

Product end of life disposal instructions



This electronic product is subject to disposal and recycling regulations that vary by country and region. It is your responsibility to recycle your electronic equipment per your local environmental laws and regulations to ensure that it will be recycled in a manner that protects human health and the environment. To find out where you can drop off your waste equipment for recycling, please contact your local waste recycle or disposal service, or the place where you purchased the product.

The European Union WEEE (Waste Electronic and Electrical Equipment) symbol on the product or its packaging indicates that this product must not be disposed of in a standard waste container.

Battery disposal instructions



Batteries contain chemicals that, if released, may affect the environment and human health. Batteries should be collected separately for recycling and recycled at a local hazardous material disposal location adhering to your country and local government regulations. To find out where you can drop off your waste battery for recycling, please contact your local waste disposal service, or the product representative. The battery used in this product is marked with the European Union symbol for waste batteries to indicate the need for the separate collection and recycling of batteries.

FCC statement

This device complies with part 15 of the FCC Rules. Operation is subject to the following two conditions: (1) This device may not cause harmful interference, and (2) this device must accept any interference received, including interference that may cause undesired operation.

CE statement

This device has been tested and found to comply with the essential requirements and other relevant provisions of the applicable EU Directives.